



## WARNING

### USE CARE TO PREVENT INJURY.

#### COMPLY WITH THE FOLLOWING TO AVOID SERIOUS PERSONAL INJURY.

1. Guards must be provided on all power transmission and conveyor applications in accordance with provisions of ANSI/ASME B 15.1 1992 and ANSI/ASME B 20.1 1993 or other applicable standards. When revisions of these standards are published, the updated edition shall apply.
2. Always lock out power switch before installing, removing, lubricating or servicing a system that uses Cam Clutch products.
3. If the Cam Clutch is used for repeated starting and stopping, make sure the strength of the supports for the Cam Clutch are sufficient.
4. The capacity of your Cam Clutch may be effected by the accuracy of its set up, the amount of pressure exerted on it, wear on other parts in your system, or wear life of the Cam Clutch itself. Check the Cam Clutch at regular intervals and take any necessary safety precautions.
5. When connecting or disconnecting Cam Clutch products, eye protection is required. Wear safety glasses, protective clothing, gloves and safety shoes.



## TSUBAKI EMERSON CO.

#### Group Companies:

**U.S. TSUBAKI, INC.**  
301 E. Marquardt Drive  
Wheeling, IL 60090  
U.S.A.  
Phone : 847-459-9500  
Facsimile : 847-459-9515

**TSUBAKI of CANADA LIMITED**  
1630 Drew Road  
Mississauga, Ontario, L5S 1J6  
Canada  
Phone : 905-676-0400  
Facsimile : 905-676-0904

**TSUBAKI AUSTRALIA PTY. LTD.**  
Unit E. 95-101 Silverwater Road  
Silverwater, N.S.W. 2128  
Australia  
Phone : 02-9648-5269  
Facsimile : 02-9648-3115

**TSUBAKIMOTO (THAILAND) CO., LTD.**  
Room No. C, T.W.Y. Office Center,  
10th Floor, Serm-Mit Tower,  
159 Soi Asoke, Sukhumvit Road,  
North-Klongtoey Wattana, Bangkok 10110  
Thailand  
Phone : 66-2-261-9991/2  
Facsimile : 66-2-261-9993

**TSUBAKIMOTO SINGAPORE PTE. LTD.**  
25 Gul Lane  
Jurong  
Singapore 629419  
Phone : 68610422/3/4  
Facsimile : 68617035

**TAIWAN TSUBAKIMOTO CO.**  
No. 7 Feng Sun Keng  
Kuei Shan-Hsiang, Taoyuan-Hsien  
Taiwan R.O.C.  
Phone : 03-3293827/8/9  
Facsimile : 03-3293065

**TSUBAKI EMERSON CO.**  
TAIWAN BRANCH  
5th Fl., No. 2, Jen Ai Road, Sec.4, Taipei  
Taiwan R.O.C.  
Phone : 02-2325-9555  
Facsimile : 02-2784-0022

1-1, Kotari-Kuresumi, Nagaokakyo, Phone : (075) 957-3131  
Kyoto 617-0833, Japan Facsimile : (075) 957-3122  
Internet:  
<http://www.tsubaki-emerson.co.jp/english/>

**TSUBAKIMOTO EUROPE B.V.**  
Belder 1, 4704 RK Roosendaal  
The Netherlands  
Phone : 0165-594800  
Facsimile : 0165-549450

**TSUBAKIMOTO U.K. LTD.**  
Osier Drive, Sherwood Park  
Annesley, Nottingham, NG15 ODX  
United Kingdom  
Phone : 01623-688788  
Facsimile : 01623-688789

**TSUBAKIMOTO CHAIN CO.**  
Shanghai Representative Office  
603 Unicom International Tower  
547 Tianmu Xi Road, Shanghai,  
China 200070  
Phone : 021-6317-1662  
Facsimile : 021-6317-0794

Distributed by:



# TSUBAKI EMERSON CAM CLUTCHES BREU SERIES



*Longer Life Lift - Off type Cam Clutches*

## BREU SERIES CAM CLUTCHES



Special shape cam for BREU series

The cam of BREU series Cam Clutch is designed to lift off and no contact with the Inner and Outer race when it overruns. This is due to centrifugal force and is the reason why this type of Cam Clutch is known as a lift off type. This Cam Clutch is suitable for “Overrunning high-speed inner race/low speed engaged outer race” or “Backstopping-high speed inner race overrunning”. BREU series Cam Clutch is a modular type Cam Clutch, whose flanges (E1, E2, E5 and E7), torque arm (E3) and Cover (E4) are standardized as a option parts. BREU series serves long wear life by lift off function for all application in each industry.

### Principle of Lift-Off

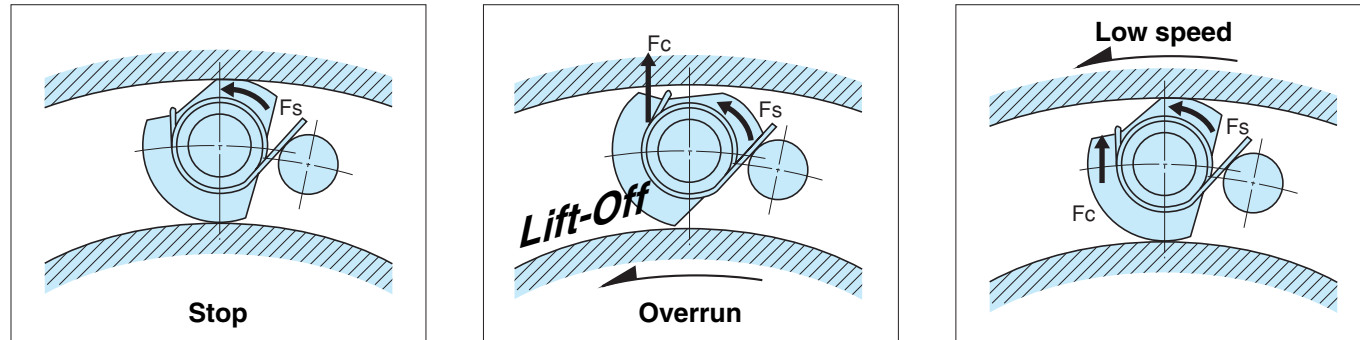

The cam engages between inner and outer race when Cam Clutch is stationary. The cam keeps no contact when the inner race, which is load side overruns at a high speed. The cam contacts to inner and outer race when the inner race (load) rotating speed becomes slow, and the outer race can drives the inner race (load) at a slow rotation speed. The cam can keep no contact between the inner and outer races during the normal machine operation to get long wear life.

### Modular Type Cam Clutch

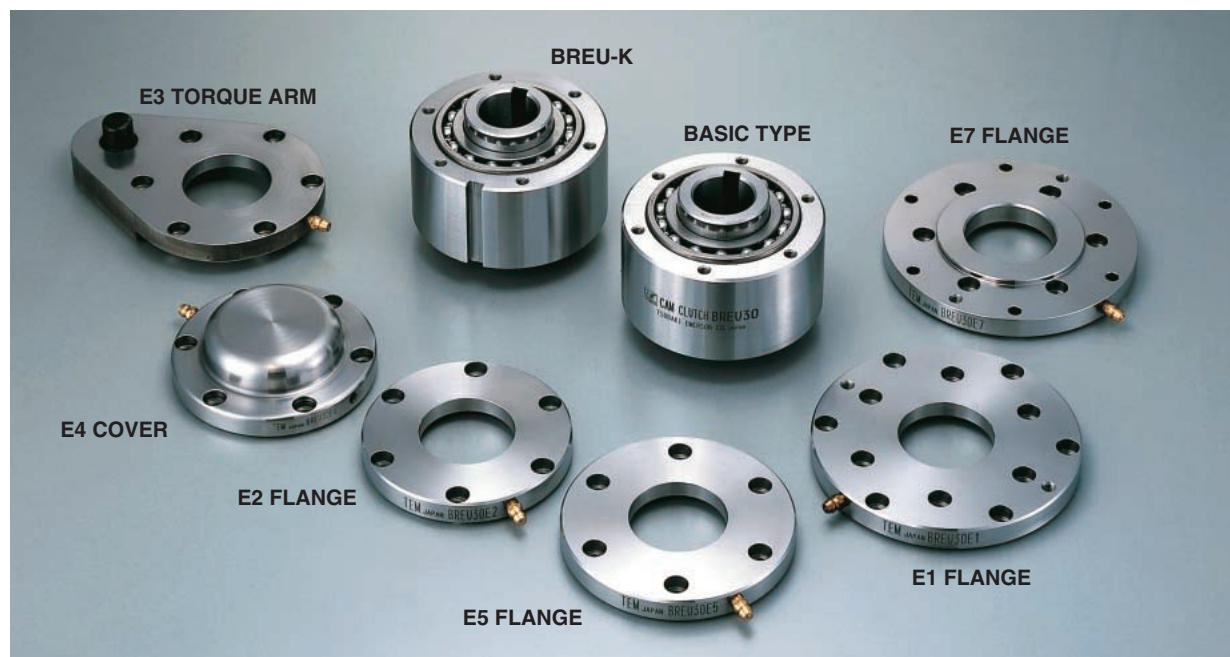

## BREU SERIES CAM CLUTCHES

### Capacity

Model	Torque Capacity	Inner Race Overrunning Speed		Max. Engagement
	N·m	Min. (r/min)	Max. (r/min)	Speed (r/min)
<b>BREU 30</b>	607	800	3,600	350
<b>BREU 35</b>	686	780	3,600	300
<b>BREU 40</b>	980	720	3,600	300
<b>BREU 45</b>	1,078	670	3,600	280
<b>BREU 50</b>	1,715	610	3,600	240
<b>BREU 55</b>	1,960	580	3,600	220
<b>BREU 60</b>	3,479	490	3,600	200
<b>BREU 70</b>	4,735	480	3,600	200
<b>BREU 80</b>	6,517	450	3,600	190
<b>BREU 90</b>	8,526	420	3,000	180
<b>BREU100</b>	14,210	460	2,500	180
<b>BREU130</b>	20,384	420	2,200	180
<b>BREU150</b>	33,908	370	1,300	180

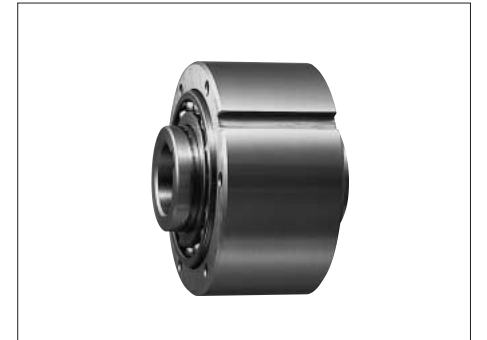

### General Information for Installation and Usage

- BREU series is a modular type Cam Clutch which is delivered as a BREU series Basic type or BREU-K series with option parts (E1, E2, E5, E7 flanges, E3 Torque arm and E4 cover) which are required as separate parts.
- All models are pre-greased.  
The operational temperature range is  $-40^{\circ}\text{C}$  to  $+40^{\circ}\text{C}$ .  
**Too much additional grease to both bearing makes any kinds of troubles to basic Cam Clutch function. Refer to page10 for the maintenance.**
- We recommend a Shaft tolerance of h7, and DIN6885.1 keyway is standard.
- We recommend tolerance of B and E H7 or H8 for sprockets, gears and other fitted parts.
- Clean the surface of both end of the outer race and the contact surfaces of the flanges, torque arm and cover.
- Verify the direction of rotation and attach the flanges, torque arm or cover.
- When installing sprocket, gear, and other equipment to the clutch, fit them on the surface of the flange by the hexagon socket cap bolt.
- By installing each option part on the opposite side, the direction of rotation can be changed.
- Fix the grease nipple and set screw to the option parts.
- When mounting the clutch onto the shaft, apply pressure to the inner race but never to the outer race. Tap the inner race lightly with a soft hammer moving around the race circumference so the Cam Clutch moves slowly and uniformly onto the end of the shaft.
- Do not use grease that contains EP additives.



# BREU SERIES CAM CLUTCHES

## BREU Basic series and BREU-K series

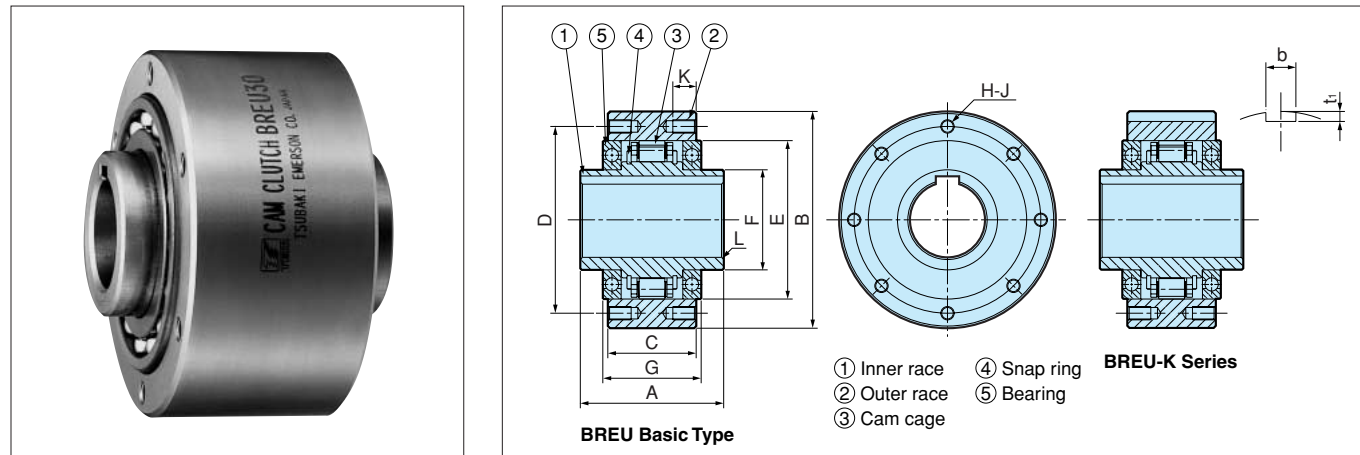

### Dimensions

Dimensions in mm

Model	Bore Size	Keyway	A	B	C	D	E	F	G	H-J	K	L	b	t <sub>1</sub>	Weight kg
	H7			h7									N9		
BREU 30	30	8 × 3.3	76	100	51	87	75	45	56	6-M6	10	1.0	8	4.0	2.7
BREU 35	35	10 × 3.3	79	110	50	96	80	50	56	6-M6	12	1.0	10	5.0	3.2
BREU 40	40	12 × 3.3	86	125	53	108	90	55	59	6-M8	14	1.5	12	5.0	4.4
BREU 45	45	14 × 3.8	86	130	53	112	95	60	59	8-M8	14	1.5	14	5.5	4.7
BREU 50	50	14 × 3.8	94	150	64	132	110	70	72	8-M8	14	1.5	14	5.5	7.6
BREU 55	55	16 × 4.3	104	160	66	138	115	75	72	8-M10	16	2.0	16	6.0	8.9
BREU 60	60	18 × 4.4	120	170	84	150	125	80	95	10-M10	16	2.0	18	7.0	12.5
BREU 70	70	20 × 4.9	134	190	95	165	140	90	108	10-M10	16	2.5	20	7.5	17.2
BREU 80	80	22 × 5.4	144	210	100	185	160	105	108	10-M10	16	2.5	22	9.0	22.4
BREU 90	90	25 × 5.4	158	230	115	206	180	120	125	10-M12	20	3.0	25	9.0	30.3
BREU100	100	28 × 6.4	186	270	124	240	210	140	135	10-M16	24	3.0	28	10.0	45.5
BREU130	130	32 × 7.4	212	310	152	278	240	160	168	12-M16	24	3.0	32	11.0	67.0
BREU150	150	36 × 8.4	246	400	180	360	310	200	194	12-M20	32	4.0	36	12.0	145.0

### Installation and Usage

1. By installing both parts on the opposite side, the direction of rotation can be changed.
2. When mounting the clutch onto the shaft, apply pressure to the inner race but never to the outer race. Tap the inner race lightly with a soft hammer moving around the race circumference so the Cam Clutch moves slowly and uniformly onto the end of the shaft.
3. All models are pre-greased.  
The ambient temperature range is -40°C to +40°C.  
**Too much additional grease to both bearing makes any kinds of troubles to basic Cam Clutch function. Refer to page10 for the maintenance.**
4. Refer to page 2 for other general information and page 10 for maintenance.

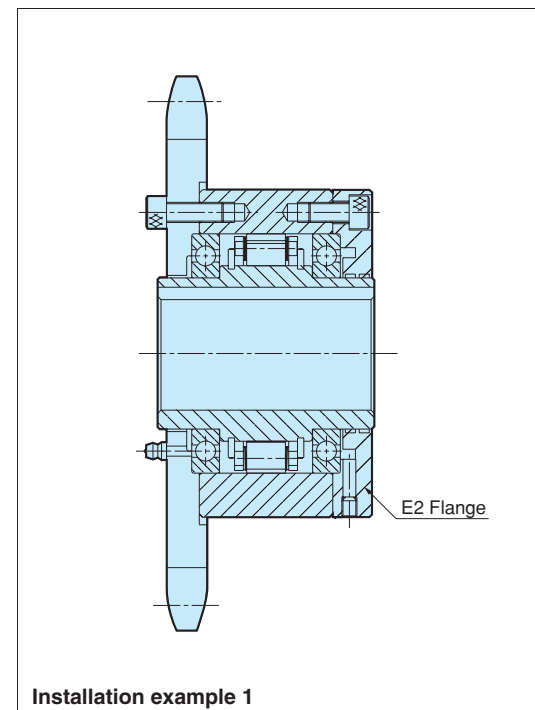

Installation example 1

# BREU SERIES CAM CLUTCHES

## E1+E2

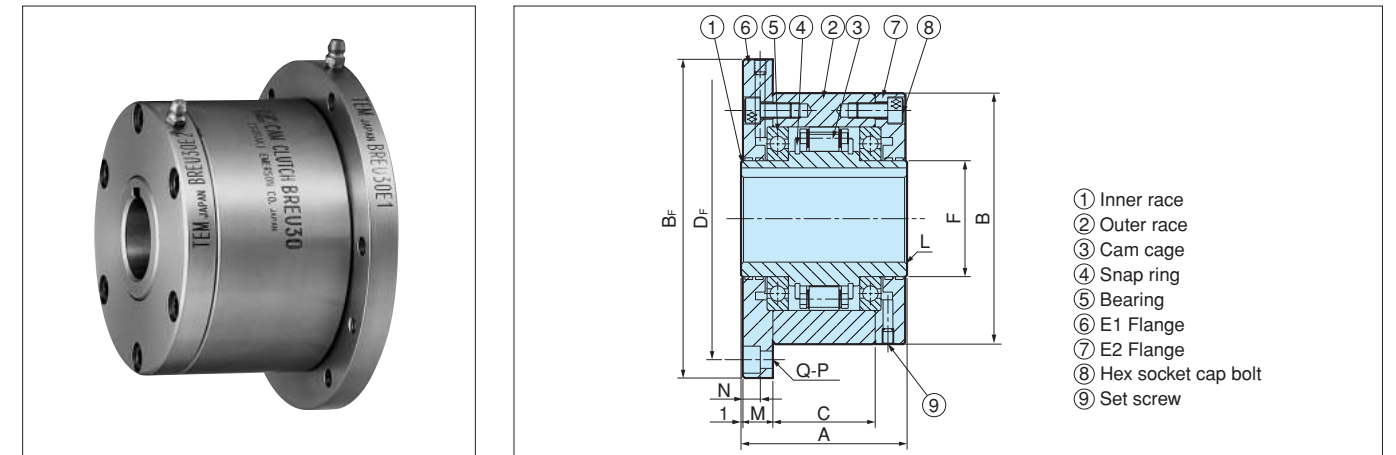

### Dimensions

Dimensions in mm

Model	Bore Size	Keyway	A	B	B <sub>f</sub>	C	D <sub>f</sub>	F	L	M	N	Q-P	Weight kg
	H7			h7									
BREU 30 E1+E2	30	8 × 3.3	76	100	128	51	114	45	1.0	11.5	6.8	6-φ 6.6	4.1
BREU 35 E1+E2	35	10 × 3.3	79	110	140	50	124	50	1.0	13.5	6.8	6-φ 6.6	5.2
BREU 40 E1+E2	40	12 × 3.3	86	125	160	53	142	55	1.5	15.5	9.0	6-φ 9.0	7.5
BREU 45 E1+E2	45	14 × 3.8	86	130	165	53	146	60	1.5	15.5	9.0	8-φ 9.0	7.9
BREU 50 E1+E2	50	14 × 3.8	94	150	185	64	166	70	1.5	14.0	9.0	8-φ 9.0	11.1
BREU 55 E1+E2	55	16 × 4.3	104	160	204	66	182	75	2.0	18.0	11.0	8-φ11.0	14.7
BREU 60 E1+E2	60	18 × 4.4	120	170	214	84	192	80	2.0	17.0	11.0	10-φ11.0	17.9
BREU 70 E1+E2	70	20 × 4.9	134	190	234	95	212	90	2.5	18.5	11.0	10-φ11.0	24.5
BREU 80 E1+E2	80	22 × 5.4	144	210	254	100	232	105	2.5	21.0	11.0	10-φ11.0	32.5
BREU 90 E1+E2	90	25 × 5.4	158	230	278	115	254	120	3.0	20.5	13.0	10-φ14.0	40.5
BREU100 E1+E2	100	28 × 6.4	186	270	335	124	305	140	3.0	30.0	18.0	10-φ18.0	68.0
BREU130 E1+E2	130	32 × 7.4	212	310	380	152	345	160	3.0	29.0	18.0	12-φ18.0	95.0
BREU150 E1+E2	150	36 × 8.4	246	400	485	180	445	200	4.0	32.0	22.0	12-φ22.0	197.0

### Installation and Usage

1. By installing E1 flange and E2 flange on the opposite side, the direction of rotation can be changed.
2. When mounting the clutch onto the shaft, apply pressure to the inner race but never to the outer race. Tap the inner race lightly with a soft hammer moving around the race circumference so the Cam Clutch moves slowly and uniformly onto the end of the shaft.
3. All models are pre-greased.  
The ambient temperature range is -40°C to +40°C.  
**Too much additional grease to both bearing makes any kinds of troubles to basic Cam Clutch function. Refer to page10 for the maintenance.**
4. Refer to page 2 for other general information and page 10 for maintenance.

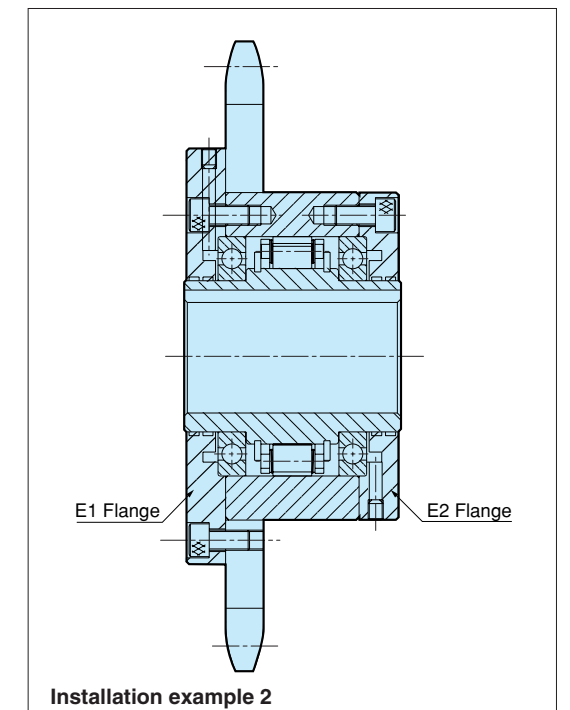

Installation example 2

# BREU SERIES CAM CLUTCHES

## E2+E3

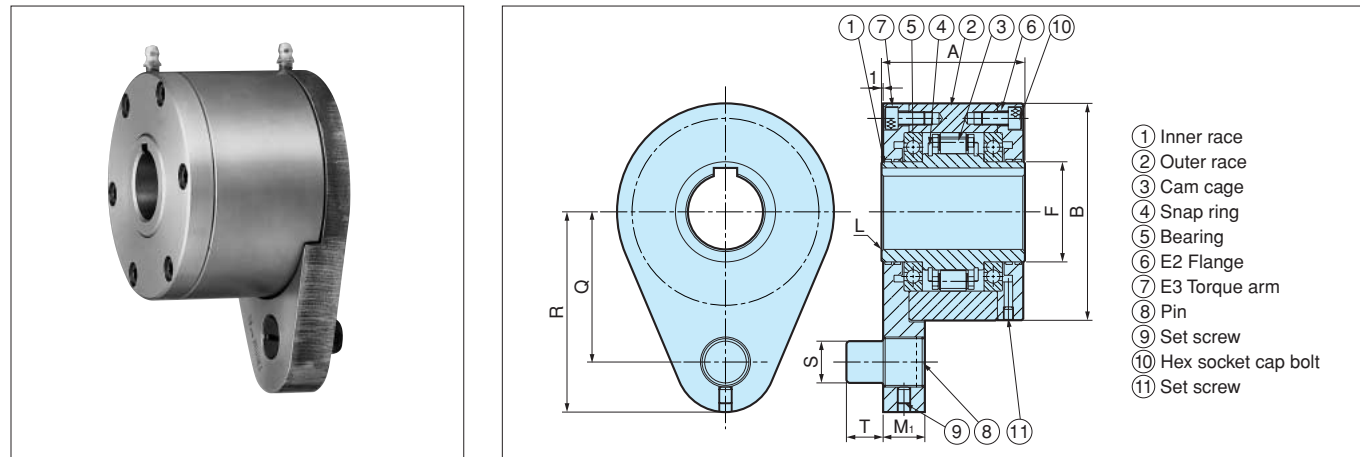

### Dimensions

Dimensions in mm

Model	Bore Size	Keyway	A	B	F	L	M <sub>1</sub>	Q	R	S	T	Weight
	H7			h7								kg
BREU 30 E2+E3	30	8 × 3.3	76	100	45	1.0	19	68	92	16	14	4.2
BREU 35 E2+E3	35	10 × 3.3	79	110	50	1.0	22	76	102	20	18	5.0
BREU 40 E2+E3	40	12 × 3.3	86	125	55	1.5	22	85	112	20	18	7.0
BREU 45 E2+E3	45	14 × 3.8	86	130	60	1.5	25	90	120	25	22	7.7
BREU 50 E2+E3	50	14 × 3.8	94	150	70	1.5	25	102	135	25	22	11.0
BREU 55 E2+E3	55	16 × 4.3	104	160	75	2.0	30	108	142	32	25	14.0
BREU 60 E2+E3	60	18 × 4.4	120	170	80	2.0	30	112	145	32	25	17.2
BREU 70 E2+E3	70	20 × 4.9	134	190	90	2.5	35	135	175	38	30	24.5
BREU 80 E2+E3	80	22 × 5.4	144	210	105	2.5	35	145	185	38	30	31.9
BREU 90 E2+E3	90	25 × 5.4	158	230	120	3.0	45	155	205	50	40	41.1
BREU100 E2+E3	100	28 × 6.4	186	270	140	3.0	45	180	230	50	40	65.0
BREU130 E2+E3	130	32 × 7.4	212	310	160	3.0	60	205	268	68	55	94.0
BREU150 E2+E3	150	36 × 8.4	246	400	200	4.0	60	255	325	68	55	190.0

### Installation and Usage

- By installing the E2 flange and E3 torque arm on the opposite side, the direction of rotation can be changed.
- When mounting the clutch onto the shaft, apply pressure to the inner race but never to the outer race. Tap the inner race lightly with a soft hammer moving around the race circumference so the Cam Clutch moves slowly and uniformly onto the end of the shaft.
- All models are pre-greased.  
The ambient temperature range is -40°C to +40°C.  
**Too much additional grease to both bearing makes any kinds of troubles to basic Cam Clutch function. Refer to page 10 for the maintenance.**
- Refer to page 2 for other general information and page 10 for maintenance.

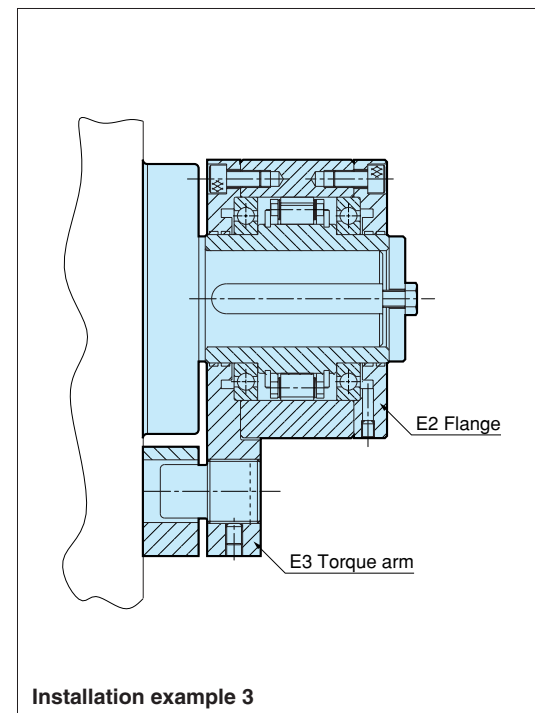

# BREU SERIES CAM CLUTCHES

## E3+E4

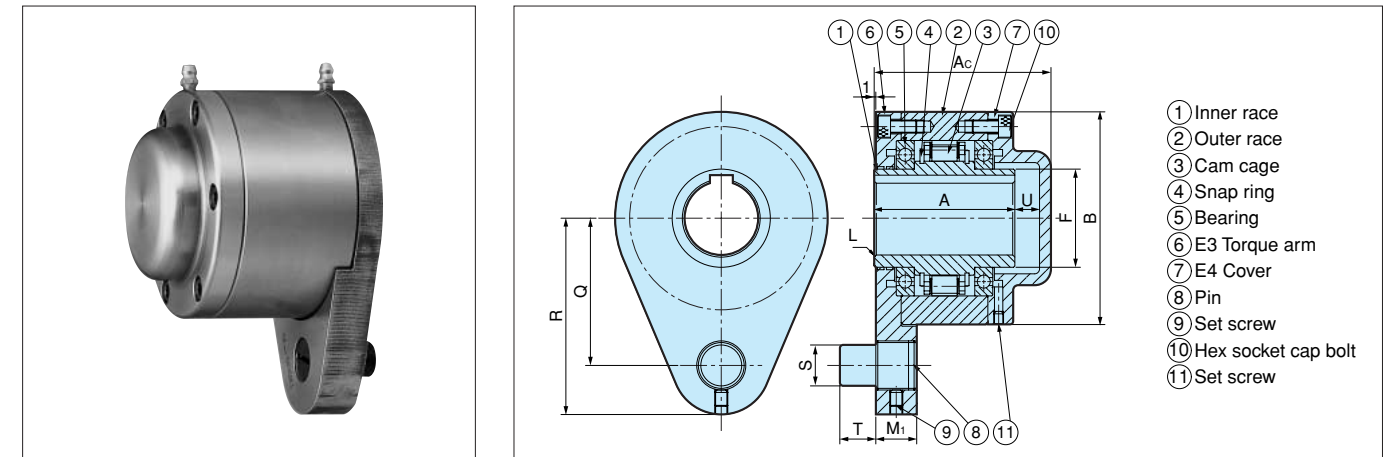

### Dimensions

Dimensions in mm

Model	Bore Size	Keyway	A	A <sub>c</sub>	B	F	L	M <sub>1</sub>	Q	R	S	T	U	Weight
	H7				h7									kg
BREU 30 E3+E4	30	8 × 3.3	76	92	100	45	1.0	19	68	92	16	14	10	4.5
BREU 35 E3+E4	35	10 × 3.3	79	97	110	50	1.0	22	76	102	20	18	12	5.3
BREU 40 E3+E4	40	12 × 3.3	86	105	125	55	1.5	22	85	112	20	18	12	7.4
BREU 45 E3+E4	45	14 × 3.8	86	108	130	60	1.5	25	90	120	25	22	15	8.1
BREU 50 E3+E4	50	14 × 3.8	94	113	150	70	1.5	25	102	135	25	22	12	11.5
BREU 55 E3+E4	55	16 × 4.3	104	126	160	75	2.0	30	108	142	32	25	15	15.6
BREU 60 E3+E4	60	18 × 4.4	120	137	170	80	2.0	30	112	145	32	25	15	18.0
BREU 70 E3+E4	70	20 × 4.9	134	164.5	190	90	2.5	35	135	175	38	30	22.5	25.5
BREU 80 E3+E4	80	22 × 5.4	144	168	210	105	2.5	35	145	185	38	30	16	32.9
BREU 90 E3+E4	90	25 × 5.4	158	192	230	120	3.0	45	155	205	50	40	16	43.4
BREU100 E3+E4	100	28 × 6.4	186	217	270	140	3.0	45	180	230	50	40	16	67.0
BREU130 E3+E4	130	32 × 7.4	212	250	310	160	3.0	60	205	268	68	55	18	97.0
BREU150 E3+E4	150	36 × 8.4	246	286	400	200	4.0	60	255	325	68	55	20	193.0

### Installation and Usage

- By installing the E3 torque arm and E4 cover on the opposite side, the direction of rotation can be changed.
- When mounting the clutch onto the shaft, apply pressure to the inner race but never to the outer race. Tap the inner race lightly with a soft hammer moving around the race circumference so the Cam Clutch moves slowly and uniformly onto the end of the shaft.
- All models are pre-greased.  
The ambient temperature range is -40°C to +40°C.  
**Too much additional grease to both bearing makes any kinds of troubles to basic Cam Clutch function. Refer to page 10 for the maintenance.**
- Refer to page 2 for other general information and page 10 for maintenance.

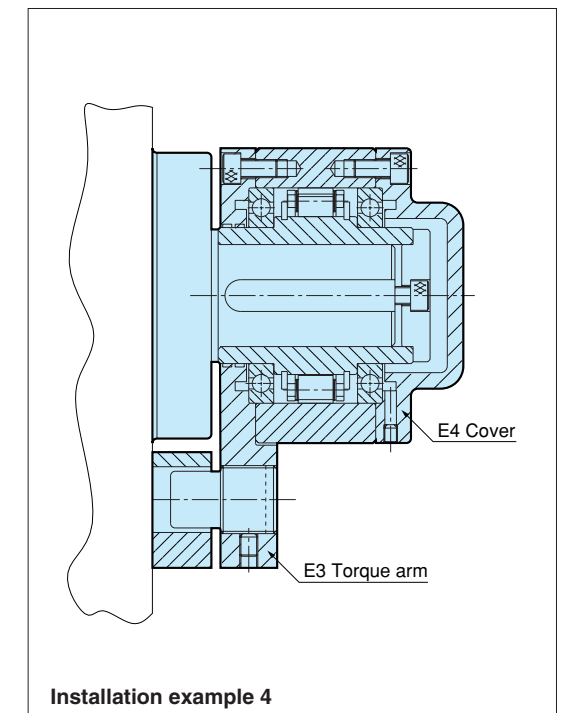

## BREU SERIES CAM CLUTCHES

### E5+E5

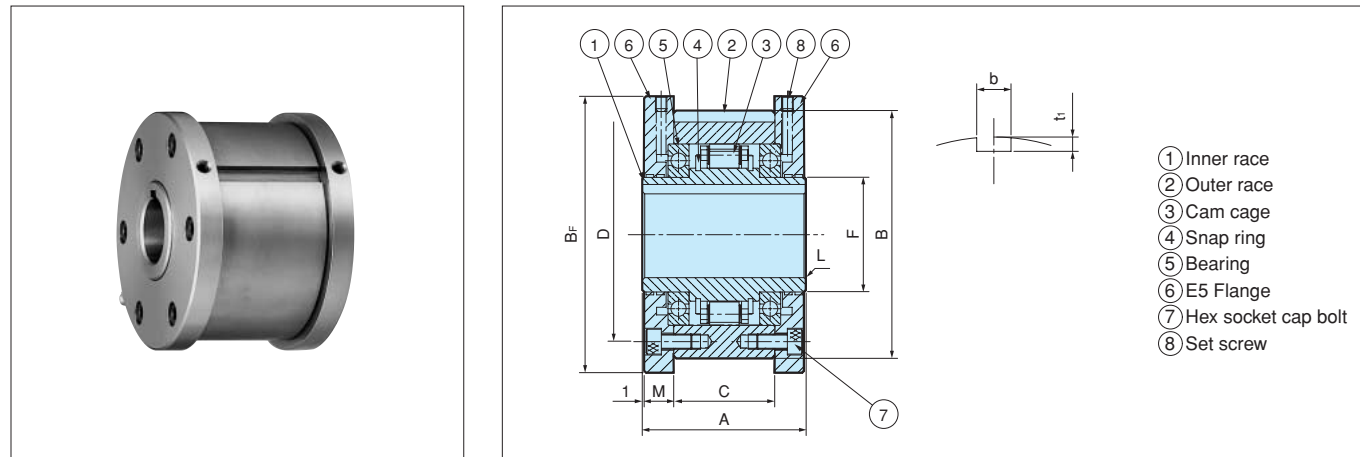

### Dimensions

Dimensions in mm

Model	Bore Size	Keyway	A	B	B <sub>F</sub>	C	D	F	L	M	b	t	Weight
	H7			h7							N9		kg
BREU 30K E5+E5	30	8 × 3.3	76	100	109	51	87	45	1.0	11.5	8	4.0	3.9
BREU 35K E5+E5	35	10 × 3.3	79	110	119	50	96	50	1.0	13.5	10	5.0	4.9
BREU 40K E5+E5	40	12 × 3.3	86	125	135	53	108	55	1.5	15.5	12	5.0	7.0
BREU 45K E5+E5	45	14 × 3.8	86	130	140	53	112	60	1.5	15.5	14	5.5	7.4
BREU 50K E5+E5	50	14 × 3.8	94	150	160	64	132	70	1.5	14.0	14	5.5	10.7
BREU 55K E5+E5	55	16 × 4.3	104	160	170	66	138	75	2.0	18.0	16	6.0	13.6
BREU 60K E5+E5	60	18 × 4.4	120	170	182	84	150	80	2.0	17.0	18	7.0	17.3
BREU 70K E5+E5	70	20 × 4.9	134	190	202	95	165	90	2.5	18.5	20	7.5	23.5
BREU 80K E5+E5	80	22 × 5.4	144	210	222	100	185	105	2.5	21.0	22	9.0	31.3
BREU 90K E5+E5	90	25 × 5.4	158	230	242	115	206	120	3.0	20.5	25	9.0	38.4
BREU100K E5+E5	100	28 × 6.4	186	270	282	124	240	140	3.0	30.0	28	10.0	63.0
BREU130K E5+E5	130	32 × 7.4	212	310	322	152	278	160	3.0	29.0	32	11.0	88.0
BREU150K E5+E5	150	36 × 8.4	246	400	412	180	360	200	4.0	32.0	36	12.0	184.0

### Installation and Usage

1. By turning the Cam Clutch on the opposite side, the direction of rotation can be changed.
2. Fix the grease nipple to the option parts.
3. When mounting the clutch onto the shaft, apply pressure to the inner race but never to the outer race. Tap the inner race lightly with a soft hammer moving around the race circumference so the Cam Clutch moves slowly and uniformly onto the end of the shaft.
4. All models are pre-greased.  
The ambient temperature range is -40°C to +40°C.  
**Too much additional grease to both bearing makes any kinds of troubles to basic Cam Clutch function. Refer to page10 for the maintenance.**
5. Refer to page 2 for other general information and page 10 for maintenance.

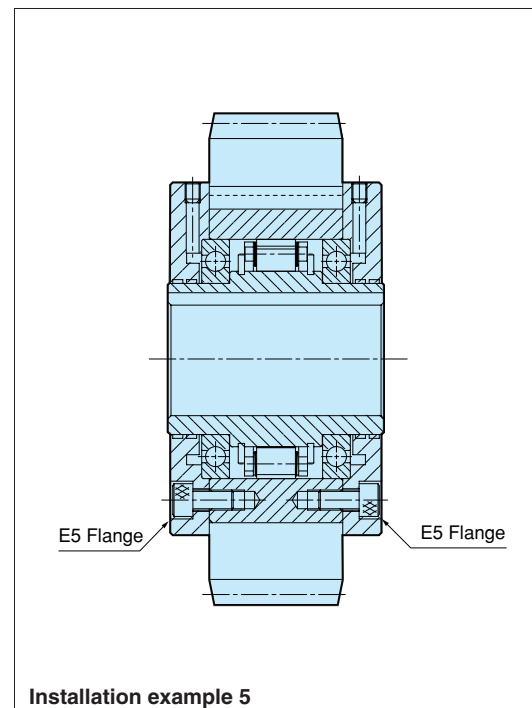

Installation example 5

## BREU SERIES CAM CLUTCHES

### E2+E7

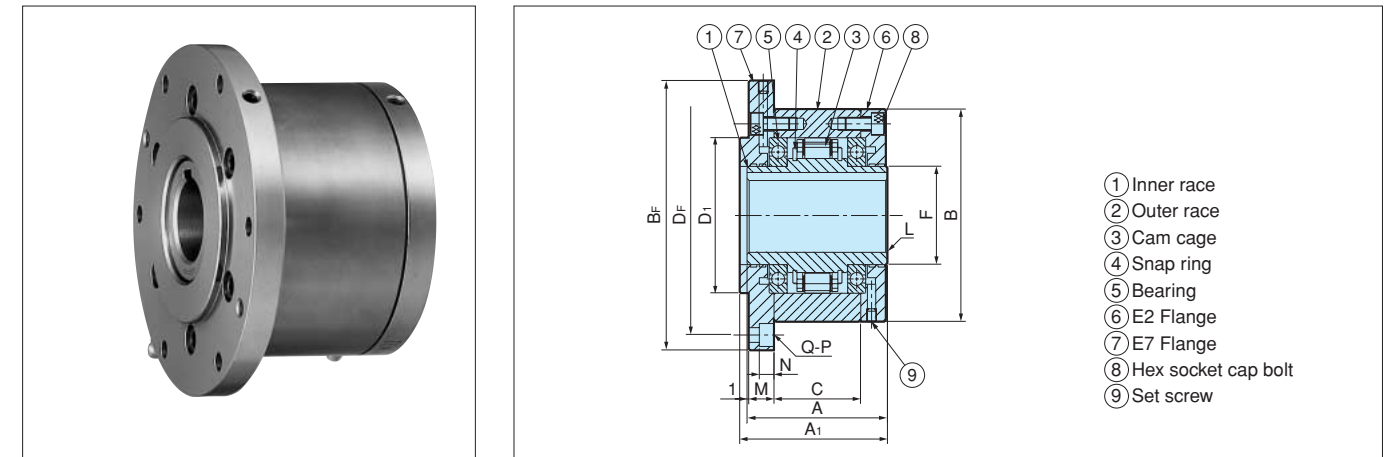

### Dimensions

Dimensions in mm

Model	Bore Size	Keyway	A	A <sub>1</sub>	B	B <sub>F</sub>	C	D <sub>1</sub>	D <sub>F</sub>	F	L	M	N	Q-P	Weight
	H7				h7			h7							kg
BREU 30 E2+E7	30	8 × 3.3	76	78	100	128	51	75	114	45	1.0	11.5	6.8	6-φ6.6	4.2
BREU 35 E2+E7	35	10 × 3.3	79	81	110	140	50	80	124	50	1.0	13.0	6.8	6-φ6.6	5.3
BREU 40 E2+E7	40	12 × 3.3	86	88	125	160	53	90	142	55	1.5	15.0	9.0	6-φ9.0	7.6
BREU 45 E2+E7	45	14 × 3.8	86	88	130	165	53	95	146	60	1.5	15.0	9.0	8-φ9.0	8.0
BREU 50 E2+E7	50	14 × 3.8	94	96	150	185	64	110	166	70	1.5	13.0	9.0	8-φ9.0	11.3
BREU 55 E2+E7	55	16 × 4.3	104	106	160	204	66	115	182	75	2.0	17.0	11.0	8-φ11.0	14.8
BREU 60 E2+E7	60	18 × 4.4	120	122	170	214	84	125	192	80	2.0	16.0	11.0	10-φ11.0	18.2
BREU 70 E2+E7	70	20 × 4.9	134	136	190	234	95	140	212	90	2.5	17.5	11.0	10-φ11.0	24.8
BREU 80 E2+E7	80	22 × 5.4	144	146	210	254	100	160	232	105	2.5	20.0	11.0	10-φ11.0	32.9
BREU 90 E2+E7	90	25 × 5.4	158	160	230	278	115	180	254	120	3.0	19.0	13.0	10-φ14.0	40.8
BREU100 E2+E7	100	28 × 6.4	186	188	270	335	124	210	305	140	3.0	28.0	17.5	10-φ18.0	69.0
BREU130 E2+E7	130	32 × 7.4	212	214	310	380	152	240	345	160	3.0	27.0	17.5	12-φ18.0	96.0
BREU150 E2+E7	150	36 × 8.4	246	248	400	485	180	310	445	200	4.0	30.0	21.5	12-φ22.0	198.0

### Installation and Usage

1. By installing the E2 flange and E7 flange on the opposite side, the direction of rotation can be changed.
2. Fix the grease nipple to the option parts.
3. When mounting the clutch onto the shaft, apply pressure to the inner race but never to the outer race. Tap the inner race lightly with a soft hammer moving around the race circumference so the Cam Clutch moves slowly and uniformly.
4. All models are pre-greased.  
The ambient temperature range is -40°C to +40°C.  
**Too much additional grease to both bearing makes any kinds of troubles to basic Cam Clutch function. Refer to page10 for the maintenance.**
5. **Too much overhang load to F7 flange also makes any kind of trouble to basic Cam Clutch function. Add one more bearing to the fixed equipment on the correct center line if the overhang load is big.**
6. Refer to page 2 for other general information and page 10 for maintenance.

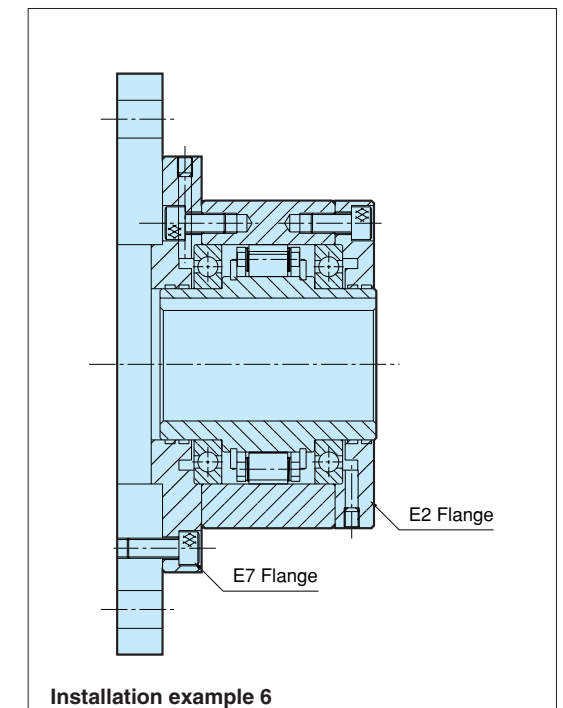

Installation example 6

## BREU SERIES CAM CLUTCHES

### COUPLING

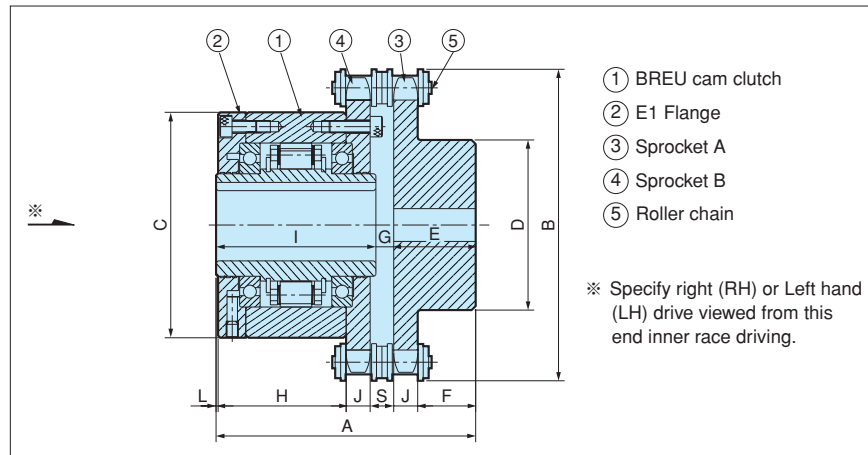
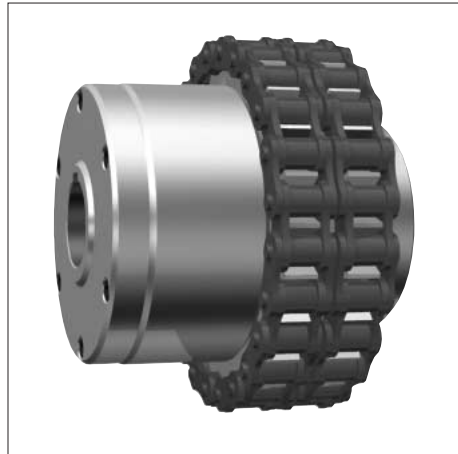

### Dimensions

Dimensions in mm

Model	Bore Size	Keyway	A	B	C	D	E	F	G	H	I	J	L	S	Weight
	H7				h7										kg
<b>BREU 30-C TK</b>	30	8 × 3.3	109.9	137	100	73	28	19.3	5.9	62.5	76	8.7	1	9.7	5.9
<b>BREU 35-C TK</b>	35	10 × 3.3	127.7	152	110	83	40	28.3	8.7	63.5	79	11.7	1	11.5	8.5
<b>BREU 40-C TK</b>	40	12 × 3.3	132.7	164	125	83	40	28.3	6.7	68.5	86	11.7	1	11.5	10.5
<b>BREU 45-C TK</b>	45	14 × 3.8	132.7	176	130	83	40	28.3	6.7	68.5	86	11.7	1	11.5	11.2
<b>BREU 50-C TK</b>	50	14 × 3.8	142.2	200	150	83	40	28.3	8.2	78.0	94	11.7	1	11.5	15.6
<b>BREU 55-C TK</b>	55	16 × 4.3	159.8	219	160	107	45	30.4	10.8	84.0	104	14.6	1	15.2	21.8
<b>BREU 60-C TK</b>	60	18 × 4.4	176.8	235	170	107	45	30.4	11.8	101.0	120	14.6	1	15.2	26.4
<b>BREU 70-C TK</b>	70	20 × 4.9	189.3	251	190	107	45	30.4	10.3	113.5	134	14.6	1	15.2	33.0
<b>BREU 80-C TK</b>	80	22 × 5.4	196.8	267	210	107	45	30.4	7.8	121.0	144	14.6	1	15.2	41.0

### Installation and Usage

- BREU-C series Cam Clutch couplings make use of BREU series Cam Clutch and CR type couplings without cover.
- Mount the clutch loosely on the high-speed shaft at first.
- Accurately align both sprockets by checking with a straight edge on the teeth of both sprockets.
- Check whether the clearance(S) between the two sprockets is correct, then wrap the chain around the sprockets.
- Specify right hand (RH) or left hand (LH) as inner race overrunning direction from the view of cam clutch side (※) when ordering. See the above drawing.
- The same lubrication as for Tsubaki roller chain is necessary for the coupling chain.
- Ensure that the chain is properly closed with a connecting link and that the closed of the spring clip is installed in the same direction as the rotation of the outer race.

## LUBRICATION AND MAINTENANCE

### Lubrication

BREU series Cam Clutches need periodic maintenance and lubrication to both bearing to provide maximum performance throughout their service life. Lack of prescribed maintenance and lubrication will shorten the Service life of Cam Clutch and may cause unnecessary mechanical damage.

### Recommended Grease

Oil Company	Ambient Temperature	
	-5°C ~ +40°C	-40°C ~ +40°C
<b>Esso</b>	Beacon 2	Beacon 325
<b>Mobil</b>	Mobilux Grease No.2	Mobil temp SHC100
<b>Shell</b>	Alvania Grease No.2	Alvania Grease RA
<b>BP</b>	Energrease LS2	Enargrease LT2
<b>TOTAL</b>	Multis 2	Aerogrease 22

**Note:** Do not use Grease that contains EP additives.

E1~E7 options are supplied with bolts for installation, and the grease nipple.

### Maintenance

BREU series Cam Clutches are pre-greased at the factory and should be re-greased every three months for both bearings after installation. Follow the procedure below.

- Remove the set screw at the flange, torque arm or cover.
- Inject equal amounts of grease into the bearing from the grease nipple. Refer to the grease volume table for the correct amount.
- Run the Cam Clutch disengaged for from 20 to 30 minutes with the set screw removed. Excess of grease in the clutch area will flow out of the tapped holes. Be careful to avoid over greasing. Too much grease in the clutch will cause it to run hot, interfere with the clutch action, and may lead to mechanical damage.
- Wipe off excess of grease and re-install the set screw.

### Grease volume table

Model	Each bearing (g)	Model	Each bearing (g)
<b>BREU30</b>	10	<b>BREU60</b>	40
<b>BREU35</b>	10	<b>BREU70</b>	50
<b>BREU40</b>	15	<b>BREU80</b>	80
<b>BREU45</b>	20	<b>BREU90</b>	90
<b>BREU50</b>	30	<b>BREU100</b>	160
<b>BREU55</b>	30	<b>BREU130</b>	260
		<b>BREU150</b>	460