



# TSUBAKI

# BS ROLLER CHAIN LAMBDA

Lube-Free Roller Chain

ISO 606 B-Series

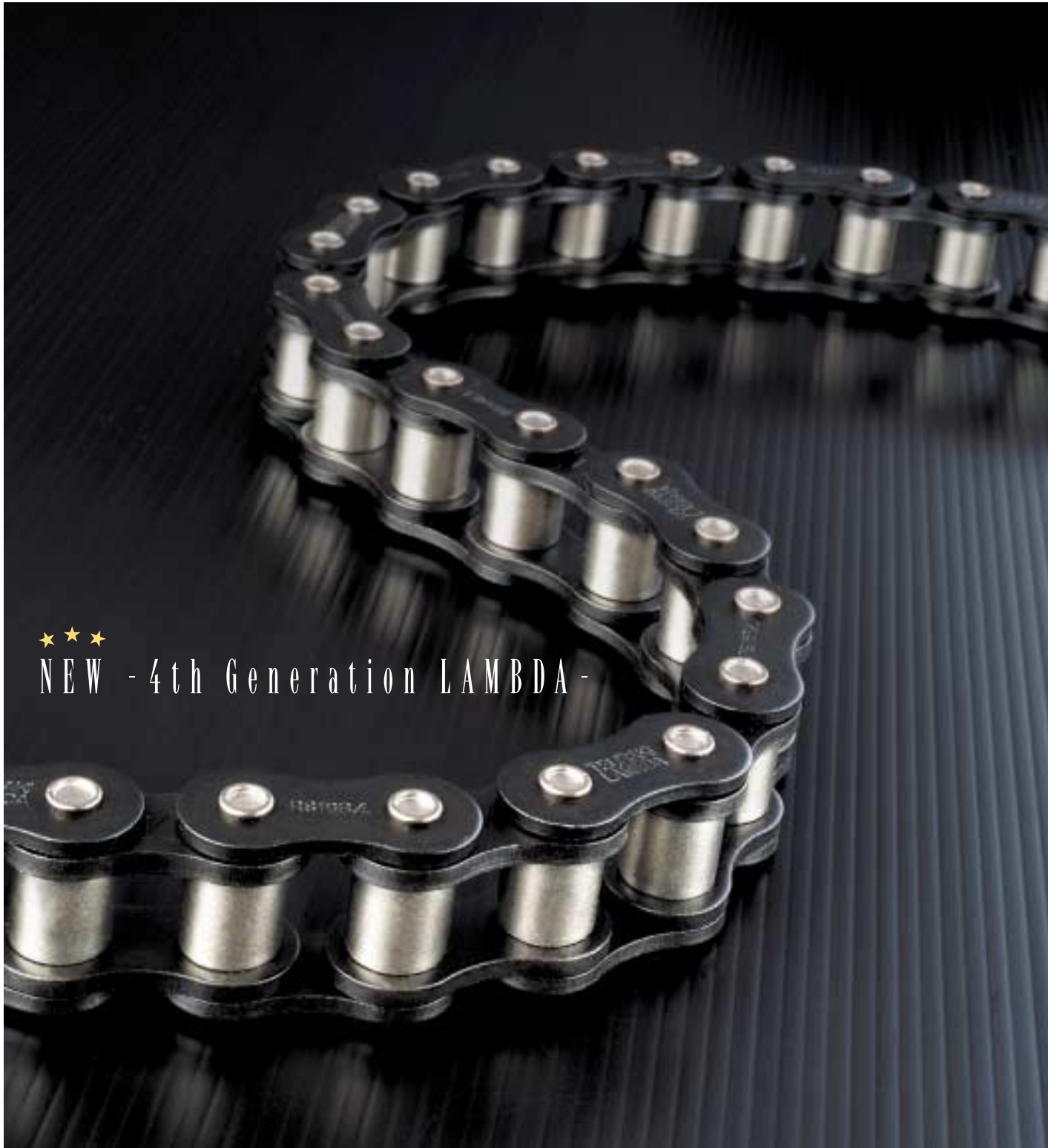

NEW - 4th Generation LAMBDA -

# Generation 4 arrives in 2005!

## ★★★ The Features of New TSUBAKI LAMBDA

### 5 New Points

- 1// Wider Range** 7 sizes are now available with the addition of RF06B, RS20B and 24B to the existing lineup of RS08B, 10B, 12B, and 16B. Standardization of single and double strand chains has also greatly increased the range of available types from 4 to 14.
- 2// Easy Disassembly** Through the adoption of newly developed special shaped pins and a new riveting style, chain can be disassembled with the aid of a chain breaker only (for single strand RS08B to 16B).
- 3// Easy Replacement** In further pursuit of BS roller chain "replacement ease," we have now made it possible to use single and double strand chains on ISO standard sprockets. Standard attachments have also been added.
- 4// Easy Adoption** Drive and conveyor chains have now been unified with emphasis being placed on the "easy adoption" of all attachment types and extended pins. The pin diameter of extended pin attachments also conforms to ISO standards.
- 5// Easy Identification** New stamping on outer plates enables end-users to recognize TSUBAKI LAMBDA more readily.

### 3 Basic Points

- 1// Long Life** Long-term operation without additional lubrication is made possible thanks to the combined effect of the special oil-impregnated bushings and specially coated pins. Compared to standard BS roller chain, wear life has been greatly improved and waste generation has been reduced.
- 2// High Strength** High fatigue strength is assured by the Ring-Coined (RC) connecting links and shot-peened parts. (NB: Not applicable for link plates with attachments)
- 3// Corrosion Resistance** Each inner and outer link plate has been individually blackened. As well as increasing corrosion resistance of the link plates, the blackening also improves the overall appearance of the chain.

New Points **2// Easy Disassembly**



Specially shaped pins and new riveting style for easy disassembly

New Points **5// Easy Identification**



New stamping for easy identification

Basic Points **1// Long Life**

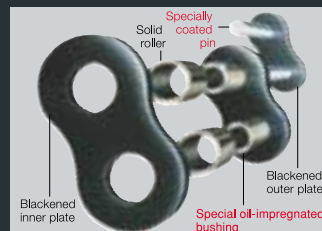

Basic construction of Lambda Chain

Basic Points **2// High Strength**



Ring Coining (RC) process for increased fatigue strength

Ever since the launch of Generation 1 Lambda Chain, RS in 1988 and BS in 1991, Tsubakimoto Chain has always supported its evolution as the pioneer of lube-free chain.

And with all the additional features offered this time, such as the enhanced line-up, easy handling capabilities, and superior lube-free performance, Tsubaki's goal is to achieve "customer delight" by supporting and contributing to your operations. You simply cannot find a better lube-free chain with comparable total cost savings.



# The History of TSUBAKI LAMBDA



- A Pallet conveyor for butter packaging (U.K.)
- B Transfer conveyor for newspapers (U.K.)
- C Materials conveying equipment for sawmill machinery (U.K.)
- D Roller conveyor for casting molds (U.K.)
- E Conveyor for printed sample sheets (France)
- F Conveyor equipment for car seats (Germany)
- G Artificial marble bar conveyor for housing construction (Austria)



NEW - 4th Generation LAMBDA -

# BS Roller Chain Lambda

ISO 606 B-Series

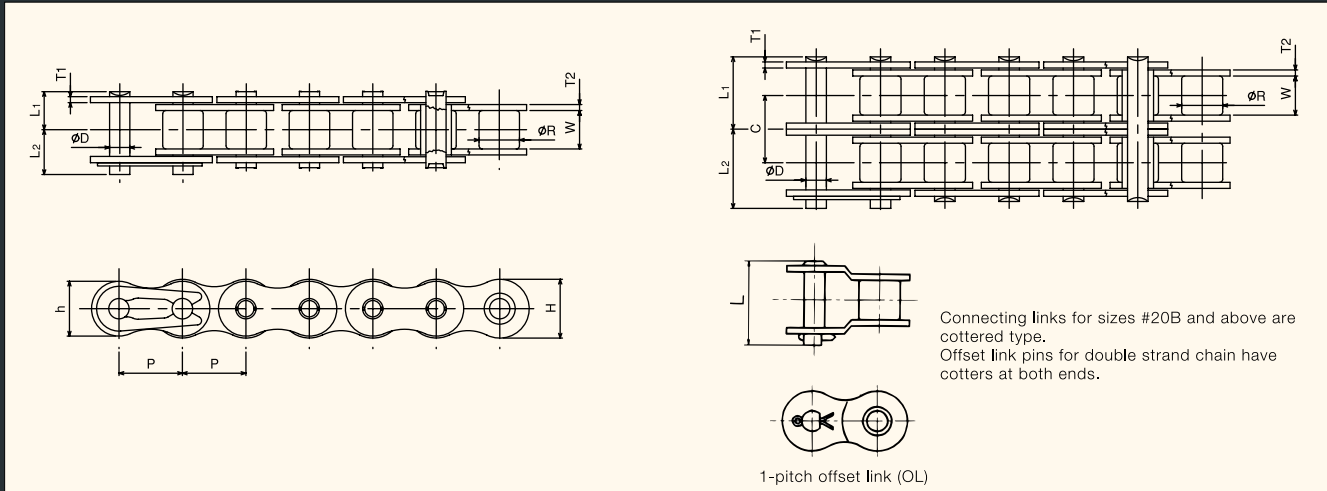

Unit:mm(inch)

Chain No.	ISO No.	Pitch P	Roller Diam. R	Width b/w Inner Plates W	Plate				Pin Diam. D
					Thickness T2	Thickness T1	Height H	Height h	
RF06B-LAMBDA	06B	9.525 (0.375)	6.35 (0.250)	5.72 (0.225)	1.3 (0.051)	1.0 (0.039)	8.2 (0.323)	8.2 (0.323)	3.28 (0.129)
RS08B-LAMBDA	08B	12.70 (0.500)	8.51 (0.335)	7.75 (0.305)	1.6 (0.063)	1.6 (0.063)	12.0 (0.473)	10.4 (0.410)	4.45 (0.175)
RS10B-LAMBDA	10B	15.875 (0.625)	10.16 (0.400)	9.65 (0.380)	1.5 (0.059)	1.5 (0.059)	14.7 (0.579)	13.7 (0.540)	5.08 (0.200)
RS12B-LAMBDA	12B	19.05 (0.751)	12.07 (0.476)	11.68 (0.460)	1.8 (0.071)	1.8 (0.071)	16.1 (0.634)	16.1 (0.634)	5.72 (0.225)
RS16B-LAMBDA	16B	25.4 (1.000)	15.88 (0.626)	17.02 (0.671)	4.0 (0.158)	3.2 (0.126)	21.0 (0.827)	21.0 (0.827)	8.28 (0.326)
RS20B-LAMBDA	20B	31.75 (1.251)	19.05 (0.751)	19.56 (0.771)	4.4 (0.173)	3.4 (0.134)	26.4 (1.040)	26.0 (1.024)	10.19 (0.401)
RS24B-LAMBDA	24B	38.1 (1.501)	25.40 (1.000)	25.40 (1.000)	6.0 (0.236)	5.6 (0.221)	33.4 (1.316)	31.2 (1.229)	14.63 (0.576)

Chain No.	No. of Strands	Pin Length			Offset Pin Length L	Transverse Pitch C	Min. Tensile Strength kN {kgf}	Approx. Mass kg/m {lbs/ft}	No. Links / 10 Feet
		L1+L2	L1	L2					
<b>RF06B-LAMBDA</b> RF06B-LAMBDA-2	1	13.8 (0.544)	6.1 (0.240)	7.7 (0.303)	15.1 (0.595)	10.24 (0.403)	8.90 {910}	0.39 {0.262}	320
	2	24.0 (0.946)	11.2 (0.441)	12.8 (0.504)	25.9 (1.020)				
<b>RS08B-LAMBDA</b> RS08B-LAMBDA-2	1	18.4 (0.725)	8.4 (0.331)	10.0 (0.394)	18.6 (0.733)	13.92 (0.548)	17.8 {1820}	0.70 {0.470}	240
	2	32.2 (1.269)	15.3 (0.603)	16.9 (0.666)	34.5 (1.359)				
<b>RS10B-LAMBDA</b> RS10B-LAMBDA-2	1	20.8 (0.820)	9.55 (0.376)	11.25 (0.443)	20.8 (0.820)	16.59 (0.654)	22.2 {2260}	0.95 {0.638}	192
	2	37.4 (1.474)	17.85 (0.703)	19.55 (0.770)	39.4 (1.552)				
<b>RS12B-LAMBDA</b> RS12B-LAMBDA-2	1	24.1 (0.950)	11.1 (0.437)	13.0 (0.512)	24.4 (0.961)	19.46 (0.767)	28.9 {2950}	1.25 {0.840}	160
	2	43.6 (1.718)	20.85 (0.821)	22.75 (0.896)	45.9 (1.808)				
<b>RS16B-LAMBDA</b> RS16B-LAMBDA-2	1	37.7 (1.485)	17.75 (0.699)	19.95 (0.786)	39.3 (1.548)	31.88 (1.256)	60.0 {6120}	2.70 {1.814}	120
	2	69.3 (2.730)	33.55 (1.322)	35.75 (1.409)	73.4 (2.892)				
RS20B-LAMBDA RS20B-LAMBDA-2	1	43.0 (1.694)	19.9 (0.784)	23.1 (0.910)	46.6 (1.836)	36.45 (1.436)	95.0 {9690}	3.85 {2.587}	96
	2	79.7 (3.140)	38.25 (1.507)	41.45 (1.633)	84.6 (3.333)				
RS24B-LAMBDA RS24B-LAMBDA-2	1	58.5 (2.305)	26.65 (1.050)	31.85 (1.255)	61.7 (2.431)	48.36 (1.905)	160 {16300}	7.45 {5.006}	80
	2	106.8 (4.208)	50.8 (2.002)	56.0 (2.206)	112.8 (4.444)				

Notes: 1. RF06B link plates are flat-shaped. 2. Intermediate link plate of RF06B and RS08B is one solid plate. 3. Min. tensile strength of attachment chain differs to the values shown above. Please contact Tsubaki.

- Ambient Temperature Range: -10°C to +150°C (+14°F to +302°F)
- Sprocket: Please use sprockets that conform to ISO Standard B Series.
- Pin Design: "Center Sink" style pins for easy disassembly are used for single strand RS08B to RS16B. Double staked riveting is used for all other sizes and double strand chain.
- Chain Selection: Please contact Tsubaki.
- Interchangeability
  - Make sure to replace the whole chain when replacing old specification chain.
  - Old specification chain and connecting parts cannot be used together with the new specification chain.

## Caution

- In dusty and dirty conditions wear will occur quickly. Moreover, in wet conditions where oil-impregnated bushing's lubrication effectiveness may be lessened, wear will occur more easily. As there is less rust preventive oil applied to the chain than BS standard roller chain, rust may occur earlier.
- Avoid using the chain in vacuum conditions as the impregnated oil comes off easily and reduces wear life of the chain.
- If the chain elongation of Lambda Chain reaches between 0.5% to 1.0% then the oil has run out. Indicators of this condition are red wear dust between the plates and occurrence of bad chain articulation. In this situation the chain is no longer usable.

### A-1 Attachment

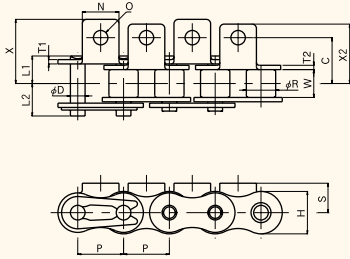

### K-1 Attachment

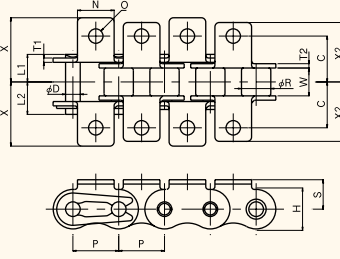

### Extended Pin Attachment

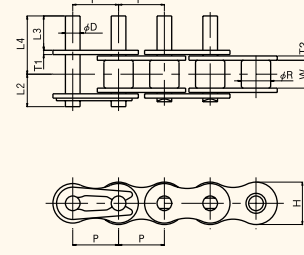

### SA-1 Attachment

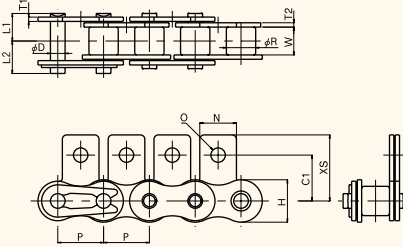

### SK-1 Attachment

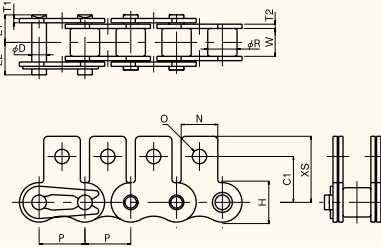

### WA-1 and WA-2 Attachment

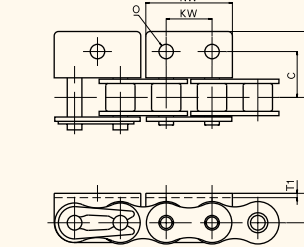

### WK-1 and WK-2 Attachment

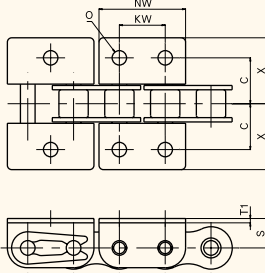

### WSA-1 and WSA-2 Attachment

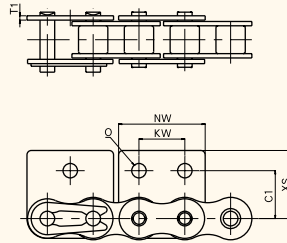

### WSK-1 and WSK-2 Attachment

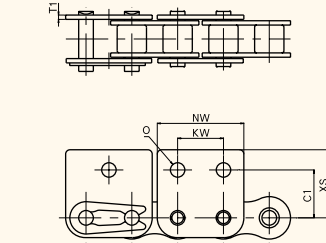

■ Attachment spacing: drawings above show attachments on every link.

■ X/X2 dimensions: X and X2 represent the attachment widths when attached to the outer and inner links respectively.

Unit:mm(inch)

Chain No.	A-1, SA-1, K-1, SK-1 Attachments								Additional Mass per Attachment kg (lbs)	
	C	C1	N	O	S	X	X2	XS	A·SA	K·SK
RS08B-LAMBDA	11.9 (0.469)	12.7(0.500)	11.4(0.449)	4.2(0.165)	8.9(0.351)	19.05(0.751)	17.15(0.676)	19.3 (0.760)	0.002 {0.004}	0.004 {0.009}
RS10B-LAMBDA	15.9 (0.626)	15.9(0.626)	12.7(0.500)	5.0(0.197)	10.2(0.402)	22.25(0.877)	20.6 (0.812)	22.9 (0.902)	0.003 {0.007}	0.006 {0.013}
RS12B-LAMBDA	19.05(0.751)	22.2(0.875)	16.5(0.650)	7.1(0.280)	13.5(0.532)	29.85(1.176)	27.8 (1.095)	32.05(1.263)	0.006 {0.013}	0.012 {0.026}
RS16B-LAMBDA	23.8 (0.938)	23.9(0.942)	24.3(0.957)	6.7(0.264)	15.2(0.599)	37.35(1.472)	34.4 (1.355)	34.1 (1.344)	0.014 {0.031}	0.028 {0.062}

Chain No.	WA-2, WSA-2, WK-2, WSK-2 Attachments WA-1, WSA-1, WK-1, WSK-1 Attachments								Extended Pin Attachment			Additional Mass per Attachment kg (lbs)		
	C	C1	NW	O	S	X	XS	KW	D	L3	L4	WA·WSA	WK·WSK	EP
RS08B-LAMBDA	12.7 (0.500)	13.1 (0.516)	24.6(0.969)	4.9(0.193)	8.9(0.351)	20.3 (0.800)	20.7 (0.816)	12.7(0.500)	4.45(0.175)	9.5(0.374)	17.0 (0.700)	0.005{0.011}	0.010{0.022}	0.001{0.002}
RS10B-LAMBDA	15.9 (0.626)	16.6(0.654)	30.0(1.182)	5.0(0.197)	10.2(0.402)	22.85(0.900)	23.6 (0.930)	15.9(0.626)	5.08(0.200)	11.9(0.469)	20.25(0.798)	0.006{0.013}	0.012{0.026}	0.002{0.004}
RS12B-LAMBDA	17.45(0.688)	17.6(0.693)	34.8(1.371)	5.5(0.217)	11.4(0.449)	25.65(1.011)	25.75(1.015)	19.1(0.753)	5.72(0.225)	14.3(0.563)	24.1 (0.950)	0.009{0.020}	0.018{0.040}	0.003{0.007}
RS16B-LAMBDA	28.6 (1.127)	26.0(1.024)	46.0(1.812)	8.1(0.319)	15.9(0.626)	39.25(1.546)	36.7 (1.446)	25.4(1.000)	8.28(0.326)	19.1(0.753)	35.25(1.389)	0.030{0.066}	0.060{0.132}	0.008{0.018}

#### Special Handling:

RF06B, RS20B and RS24B attachment chain as well as special attachments and extended pins with dimensions other than those shown above can also be manufactured. Please consult Tsubaki.

#### Caution

- D-dimension of pin end is slightly wider for extended pin attachments.
- Actual P' dimensions of extended pin attachments differ to that of the P dimensions. Please consult Tsubaki.
- D-dimensions of extended pin attachments differ to that of the old specification (excluding RS10B).
- Refer to dimensions table on left page for base chain dimensions.
- When replacing European-made standard attachment chain with Lambda Chain, we recommend confirming attachment dimensions in advance, as Tsubaki standard dimensions may differ.

#### Model Identification

# RS08B-LAMBDA-1LA1

Chain No.

Attachment Spacing

Attachment Type

## USE CARE TO PREVENT INJURY



### WARNING

Comply with the following to avoid serious personal injury.

- Do not carry out any rework on the chain under any circumstances.
- Do not anneal any parts of the roller chain.
- Do not wash roller chain with acidic or alkaline solutions. This may result in cracking.
- Avoid electroplating of the roller chain and its parts since it may lead to cracking caused by hydrogen embrittlement.
- Avoid welding on the chain. This will decrease the strength of the chain and cause cracking.
- If parts are heated or cut by a torch, the links beside the affected part should be removed and discarded.
- Avoid replacing only parts that are partially worn or damaged with new parts.  
The whole chain should be replaced in such cases.
- Install barriers and clear the area of all personnel below the items being lifted when using roller chain in lifting applications.
- Install safety devices (safety covers, etc.) on all roller chain and sprockets.
- When connecting, disconnecting, maintaining & inspecting and lubricating,
  - Carry out all steps according to our catalog or manual.
  - Always lock out the power switch and prevent accidental activation of power in advance.
  - Connect the chain firmly to prevent unexpected movement of chain and parts.
  - Correctly use pressing equipment and other exclusive tools for disconnecting/connecting.
- Make sure to wear suitable work clothes and protective equipment (safety glasses, gloves and safety shoes).
- Ensure that only skilled people carry out chain replacement.



### NOTE

Comply with the following to prevent accidents.

- Only handle chain after understanding its construction and specifications.
- Please inspect in advance whether there is any damage at the time of transportation when installing the chain.
- Make sure to carry out periodical maintenance and inspection of the chain and sprockets.
- Chain strength differs depending on the manufacturer. Ensure that TSUBAKI products are used when selection is carried out based on TSUBAKI's catalog.
- The minimum tensile strength is the minimum load that will cause the chain to fail when such a load is applied once to the chain. This is not an allowable load.
- Nickel Plating
  - Do not use under any circumstances where the chain comes into direct contact with food products and/or where coating flakes or wear dust may mix with and contaminate such products.
  - Even in non-food applications, if the chain is used in an environment where coating flakes or wear dust may pose a problem, please install a suitable cover or consult with Tsubaki for chain selection advice.



## TSUBAKIMOTO CHAIN CO.

#### Headquarters

Fukokuseimei Building 7F  
2-4, Komatsubara-cho  
Kita-ku, Osaka 530-0018, Japan  
Phone : 06-6313-3131  
Facsimile : 06-6313-6657

#### Internet:

<http://tsubakimoto.com>

#### Affiliated Companies:

##### U.S. TSUBAKI, INC.

301 E. Marquardt Drive  
Wheeling, IL 60090  
U.S.A.  
Phone : 847-459-9500  
Facsimile : 847-459-9515

##### TSUBAKI AUSTRALIA PTY. LTD.

Unit E. 95-101 Silverwater Road  
Silverwater, N.S.W. 2128  
Australia  
Phone : 02-9648-5269  
Facsimile : 02-9648-3115

##### TSUBAKIMOTO CHAIN TRADING (SHANGHAI) CO., LTD.

Room 1712, Lippo Plaza,  
No.222 Huai Hai Zhong Rd.  
Shanghai China 200021  
Phone : 021-5396-6651/2  
Facsimile : 021-5396-6628

#### Chain Division

##### Marketing Department

1-3, Kannabidai 1-chome  
Kyotanabe Kyoto 610-0380, Japan  
Phone : 0774-64-5022/3/4/5  
Facsimile : 0774-64-5212

For further information please  
contact the Chain Division.

##### TSUBAKIMOTO EUROPE B.V.

Belder 1, 4704 RK Roosendaal  
The Netherlands  
Phone : 0165-594800  
Facsimile : 0165-549450

##### TAIWAN TSUBAKIMOTO CO.

No. 7 Feng Sun Keng  
Kuei Shan-Hsiang, Taoyuan-Hsien  
Taiwan R.O.C.  
Phone : 033-293827/8/9  
Facsimile : 033-293065

##### KOREA CONVEYOR IND. CO., LTD.

72-1 Onsoo-Dong  
Kuro-Ku, Seoul,  
Korea  
Phone : 82-2-2619-4711  
Facsimile : 82-2-2619-0819



Kyotanabe Plant

##### TSUBAKI of CANADA LIMITED

1630 Drew Road  
Mississauga, Ontario, L5S 1J6  
Canada  
Phone : 905-676-0400  
Facsimile : 905-676-0904

##### TSUBAKIMOTO U.K. LTD.

Osier Drive, Sherwood Park  
Annesley,  
Nottingham NG15 0DX U.K.  
Phone : 01623-688-700  
Facsimile : 01623-688-789

##### TSUBAKIMOTO SINGAPORE PTE. LTD.

25 Gul Lane  
Jurong  
Singapore 629419  
Phone : 68610422/3/4  
Facsimile : 68617035

##### TSUBAKIMOTO (THAILAND) CO., LTD.

Room No. C, T.W.Y. Office Center,  
10th Floor, Serm-Mit Tower,  
159 Soi Asoke, Sukhumvit Road,  
North-Klongtoey Wattana, Bangkok 10110  
Thailand  
Phone : 66-2-261-9991/2  
Facsimile : 66-2-261-9993

Distributed by: