

Tsubaki is eliminating all surface coated chains that contain designated hazardous chemicals* and working towards reducing our environmental load.

* Hexavalent chromium, cadmium, lead, etc.



In order to reduce our environmental load, Tsubaki has developed a unique eco-friendly surface coating, featured on our new NEP Chain. NEP Chain (New Environmental Plating Chain) has superior corrosion resistance than our WP or DP Chains, reducing its load on the environment.

NEP Surface Coating Structure

NEP Chain is a tough coated chain with two different optimized coatings for its different parts. (See below.) These special coatings have high corrosion resistance and protect the chain from corrosive environments.



Superior Corrosion Resistance

No rust appeared on the NEP Chain even after 700hrs in a salt spray test. (JIS-Z-2371)

2.3 times the anti-rust performance of WP Chain and **1.4 times** that of DP!



In-house salt spray test results of NP, WP, DP, and NEP Chains

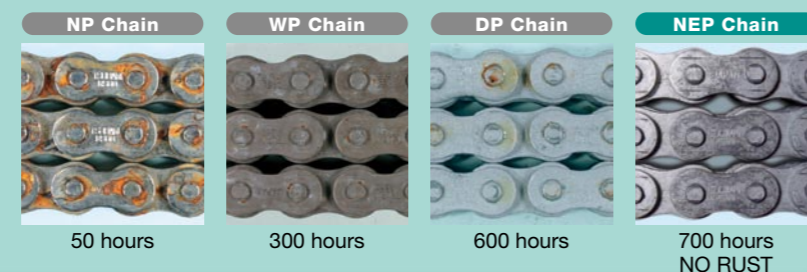

Environmentally Friendly

NEP Chains use no harmful hexavalent chromium in their anti-rust surface treatment, nor any other hazardous substances such as lead, cadmium, mercury, or arsenic. NEP Chain complies with RoHS.



RoHS (Restriction of the Use of Certain Hazardous Substances in Electrical Equipment)
RoHS is a directive issue by the European Union limiting the use of specified hazardous substances in electronics or electrical equipment.

Deviation-free Parts Processing Control

The individual parts of NEP Chains are surface treated - and unlike chains treated after assembly, even the inner parts of NEP Chains are treated.

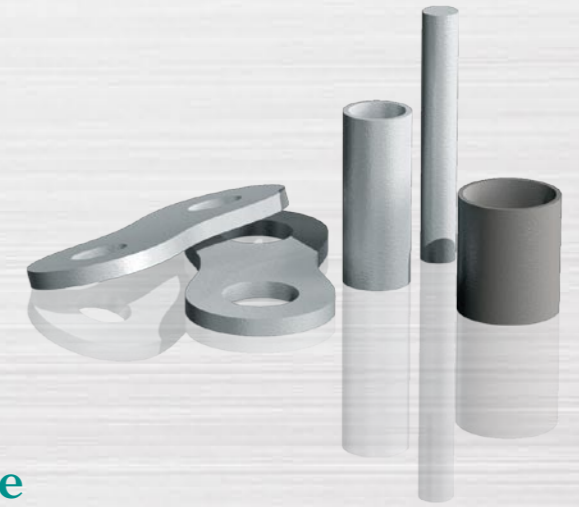

Superior Corrosion Resistance

Features superior comprehensive anti-corrosion properties for outdoor use.

No Strength Reduction

Chain strength (part hardness) is unaffected thanks to low treatment temperatures. Thus, NEP Chains have the same tensile strength and allowable load as our standard Roller Chains.

	Standard Chain	NEP Chain	Zinc Chromium Compound	NP Chain	Stainless Steel
Minimum Tensile Strength	17.7 {1800}	17.7 {1800}	16.6* {1690}	17.7 {1800}	—
Maximum Allowable Load	3.63 {370}	3.63 {370}	—	3.04 {310}	0.44 {45}

Unit: kN (kgf)
Ref: With RS40 (Drive Chain)
*Competitor Average Tensile Strength

Peeling

The coating on chain rollers peels when they engage the sprocket. However, the peeling from NEP Chains is finer than DP Chains. (Same as WP Chain)

Peeling flakes from WP, DP, and NEP Chains

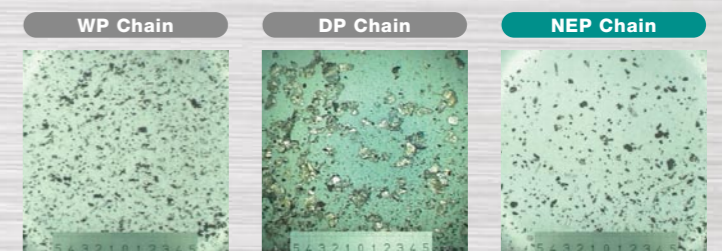

Product Digest and Applications

NEP lives up to the expectations of customers in corrosive environments.

*Applications are based on actual DP results

NEP ANSI Drive Series

Chain Sizes

RS35-1 – RS160-1
RS40-2 – RS100-2

Stocked Products

RS35-1 – RS100-1
(Unit Stock)



In Roller Conveyors For Car Wash

Application: Drive for car wash roller conveyor, brush, and blower
Environment: Sprayed with water and cleaning solution

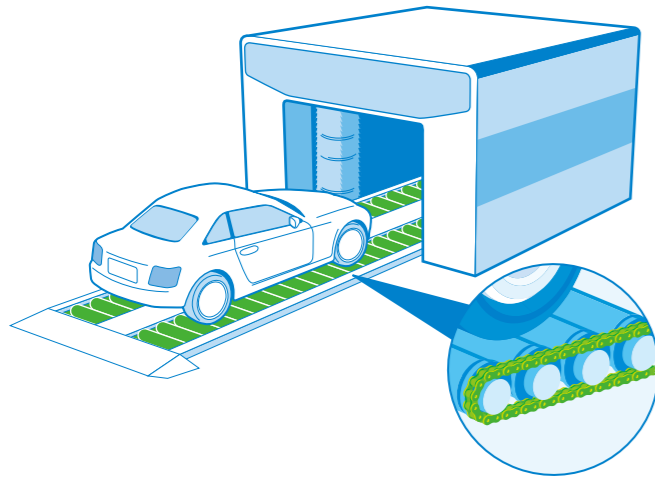

In Automated Warehouses

Application: Lifting chain for stacker cranes in mushroom cultivation
Environment: High temperature/humidity

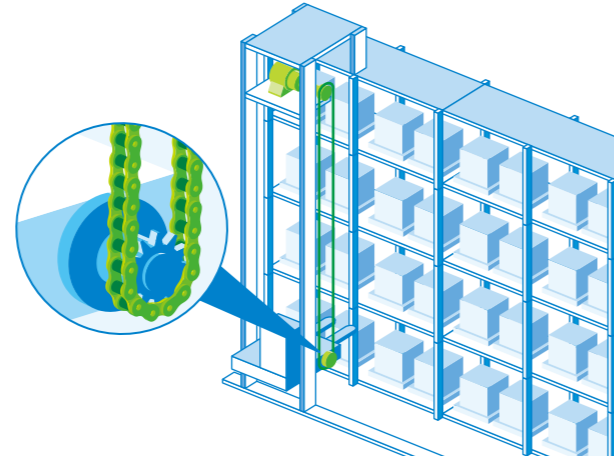

In Roller Conveyors For Case Cleaning

Application: Drive for Roller conveyors for pin case cleaning
Environment: Sprayed with cleaning solution

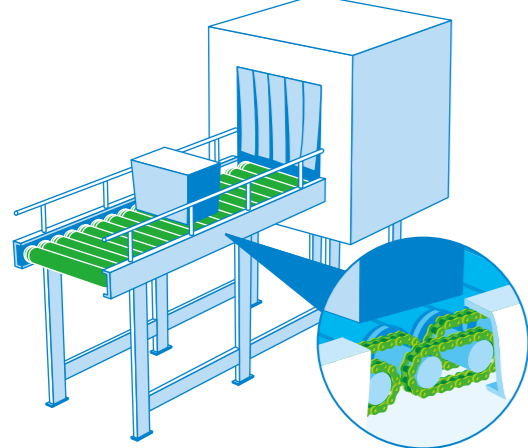

In Outdoor Conveyor Drives (Coastal Environments)

Application: Drive for flow conveyor
Environment: Frequent exposure to sea spray

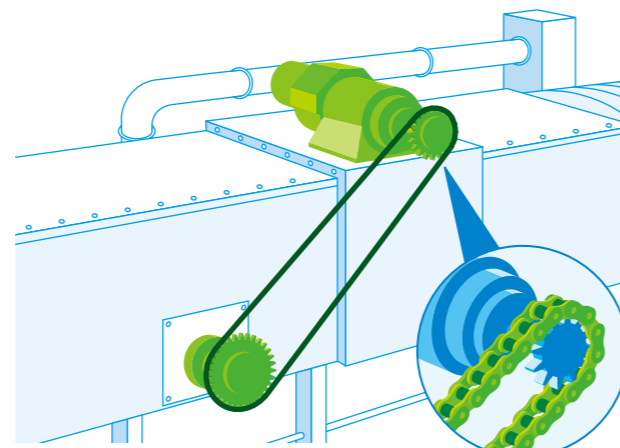

NEP ANSI Conveyor Series

■ NEP RS Chain with Attachments

Chain Sizes

RS40, RS50, RS60,
RS80, RS100

Attachments

A1, SA1, K1, SK1



In Vertical Conveyors

Application: Food tray conveyor in fermenting chambers
Environment: High humidity, regular cleaning (wash down)

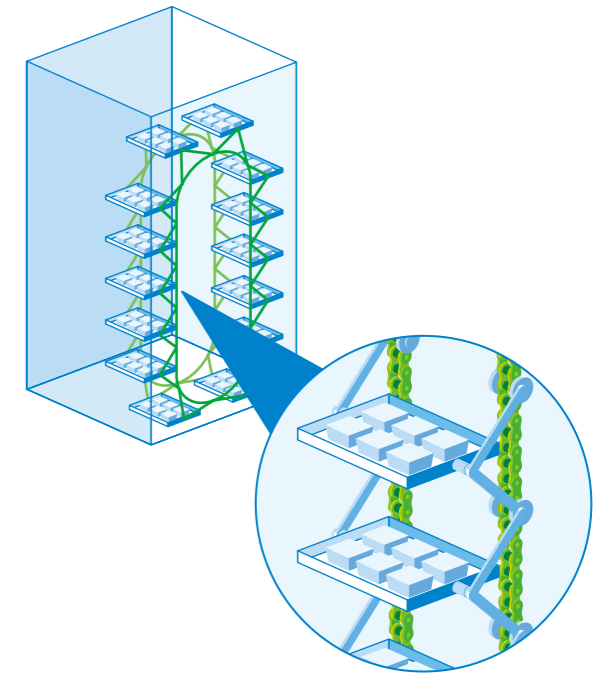

■ NEP Double Pitch Chain

Chain Sizes

RF2040, RF2050, RF2060,
RF2080, RF2100

Attachments

A, SA, K, SK



NEP Large Size Conveyor

Chain Sizes

RF03, RF05, RF08, RF10,
RF12, RF17, RF36

Attachments

A, K, GA



In Vehicle Conveyors

Application: Vehicle inspection line
Environment: Sprayed with water

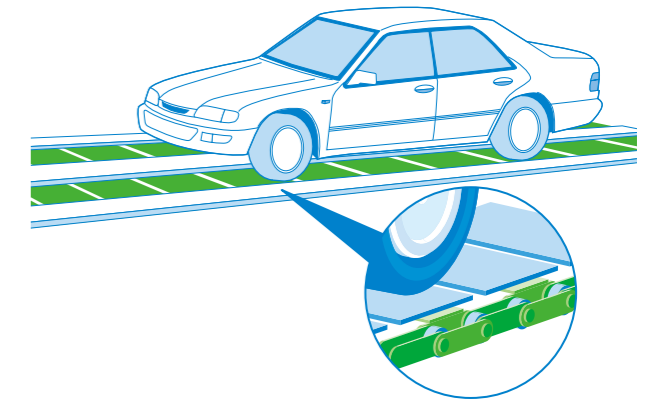

*RS" is a registered trademark of Tsubakimoto Chain Co.

NEP ANSI Drive Series

Chain Numbering Example

RS50-NEP-1

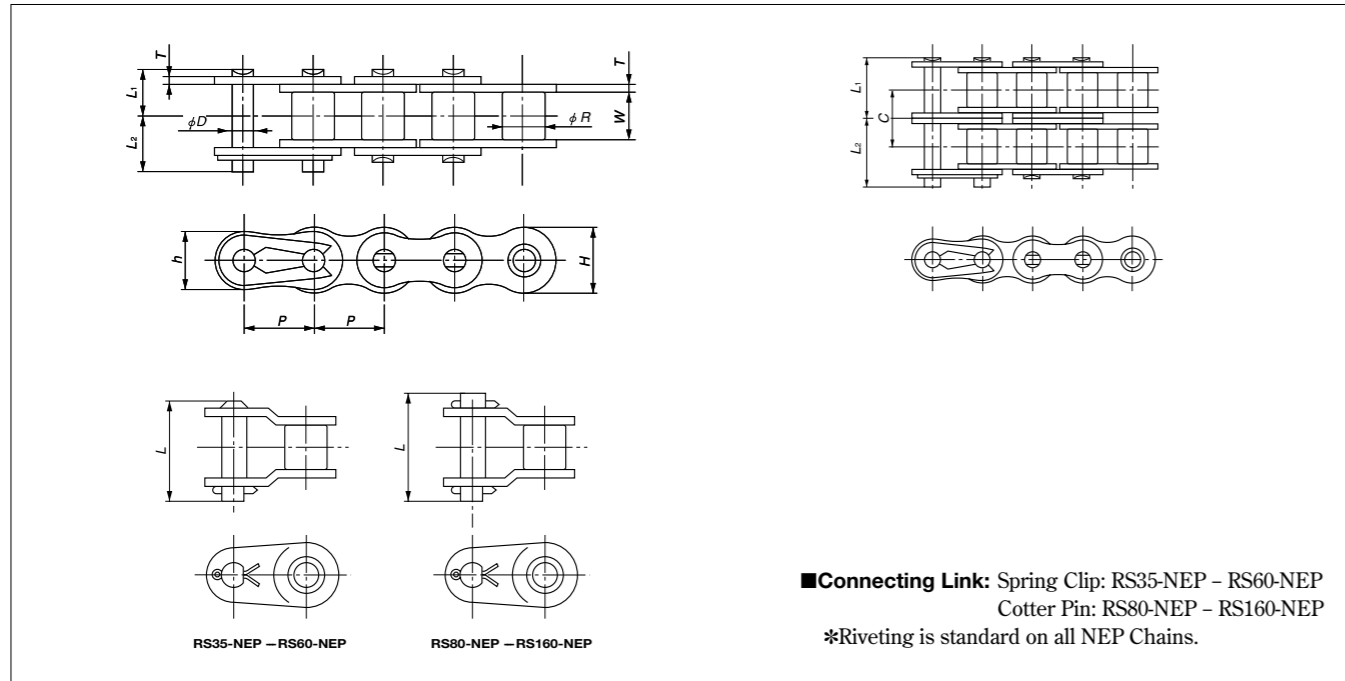

TSUBAKI Chain Number	Pitch P	Roller Dia. (Bushing Dia.) R	Inner Width of Inner Link W	Plate			Diameter D	Pin				Transverse Pitch C
				Thickness T	Height H	Height h		L ₁ +L ₂	L ₁	L ₂	Offset Pin Length L	
RS35-NEP-1	9.525	(5.08)	4.78	1.25	9.0	7.8	3.59	12.7	5.85	6.85	13.5	-
RS40-NEP-1	12.70	7.92	7.95	1.5	12.0	10.4	3.97	18.2	8.25	9.95	18.2	-
RS40-NEP-2								32.6	15.45	17.15	33.5	14.4
RS50-NEP-1	15.875	10.16	9.53	2.0	15.0	13.0	5.09	22.3	10.3	12.0	22.6	-
RS50-NEP-2								40.5	19.35	21.15	41.8	18.1
RS60-NEP-1	19.05	11.91	12.70	2.4	18.1	15.6	5.96	27.6	12.85	14.75	28.2	-
RS60-NEP-2								50.5	24.25	26.25	52.6	22.8
RS80-NEP-1	25.40	15.88	15.88	3.2	24.1	20.8	7.94	35.5	16.25	19.25	38.2	-
RS80-NEP-2								64.8	30.9	33.9	67.5	29.3
RS100-NEP-1	31.75	19.05	19.05	4.0	30.1	26.0	9.54	42.6	19.75	22.85	45.7	-
RS100-NEP-2								78.5	37.7	40.8	81.5	35.8
RS120-NEP-1	38.10	22.23	25.40	4.8	36.2	31.2	11.11	53.8	24.9	28.9	57.8	-
RS140-NEP-1	44.45	25.40	25.40	5.6	42.2	36.4	12.71	58.6	26.9	31.7	63.4	-
RS160-NEP-1	50.80	28.58	31.75	6.4	48.2	41.6	14.29	68.7	31.85	36.85	73.6	-

TSUBAKI Chain Number	Minimum Tensile Strength kN[kgf]	Maximum Allowable Load kN[kgf]	Approximate Mass kg/m	Links per Unit
RS35-NEP-1	9.81 { 1000 }	2.16 { 220 }	0.33	320
RS40-NEP-1	17.7 { 1800 }	3.63 { 370 }	0.64	
RS40-NEP-2	35.3 { 3600 }	6.18 { 630 }	1.27	240
RS50-NEP-1	28.4 { 2900 }	6.37 { 650 }	1.04	
RS50-NEP-2	56.9 { 5800 }	10.7 { 1100 }	2.07	192
RS60-NEP-1	40.2 { 4100 }	8.83 { 900 }	1.53	
RS60-NEP-2	80.4 { 8200 }	15.0 { 1530 }	3.04	160
RS80-NEP-1	71.6 { 7300 }	14.7 { 1500 }	2.66	
RS80-NEP-2	143 { 14600 }	25.0 { 2550 }	5.27	120
RS100-NEP-1	107 { 10900 }	22.6 { 2300 }	3.99	
RS100-NEP-2	214 { 21800 }	38.3 { 3910 }	7.85	96
RS120-NEP-1	148 { 15100 }	30.4 { 3100 }	5.93	
RS140-NEP-1	193 { 19700 }	40.2 { 4100 }	7.49	68
RS160-NEP-1	255 { 26000 }	53.0 { 5400 }	10.10	60

1. Maximum allowable load is 65% of the above values when using a one-pitch offset link.
2. RS35-NEP is a bushed chain.
3. Multi-strand RS35-NEP unavailable.
4. 2POL unavailable.

Operating Temperature Range:

-10°C - 150°C
(Use a high temperature lubricant when using above 60°C. Contact a Tsubaki representative when using in temperatures beyond the ranges given.)

Selection/Handling:

Refer to the Tsubaki Drive Chains catalog for information on selection and handling. Catalog No.120

Precautions on Use:

Electrical corrosion may occur when steel chains are used with stainless steel sprockets, promoting premature wear. Avoid mutual contact as much as possible. In-house tests have shown that the middle links of multi-strand chains have slightly less corrosion resistance than with single-strand chains.

BS/DIN Drive Series is available.

Please contact TSUBAKI representative.

NEP ANSI Conveyor Series

Chain Numbering Example

RS50-NEP-1L A1

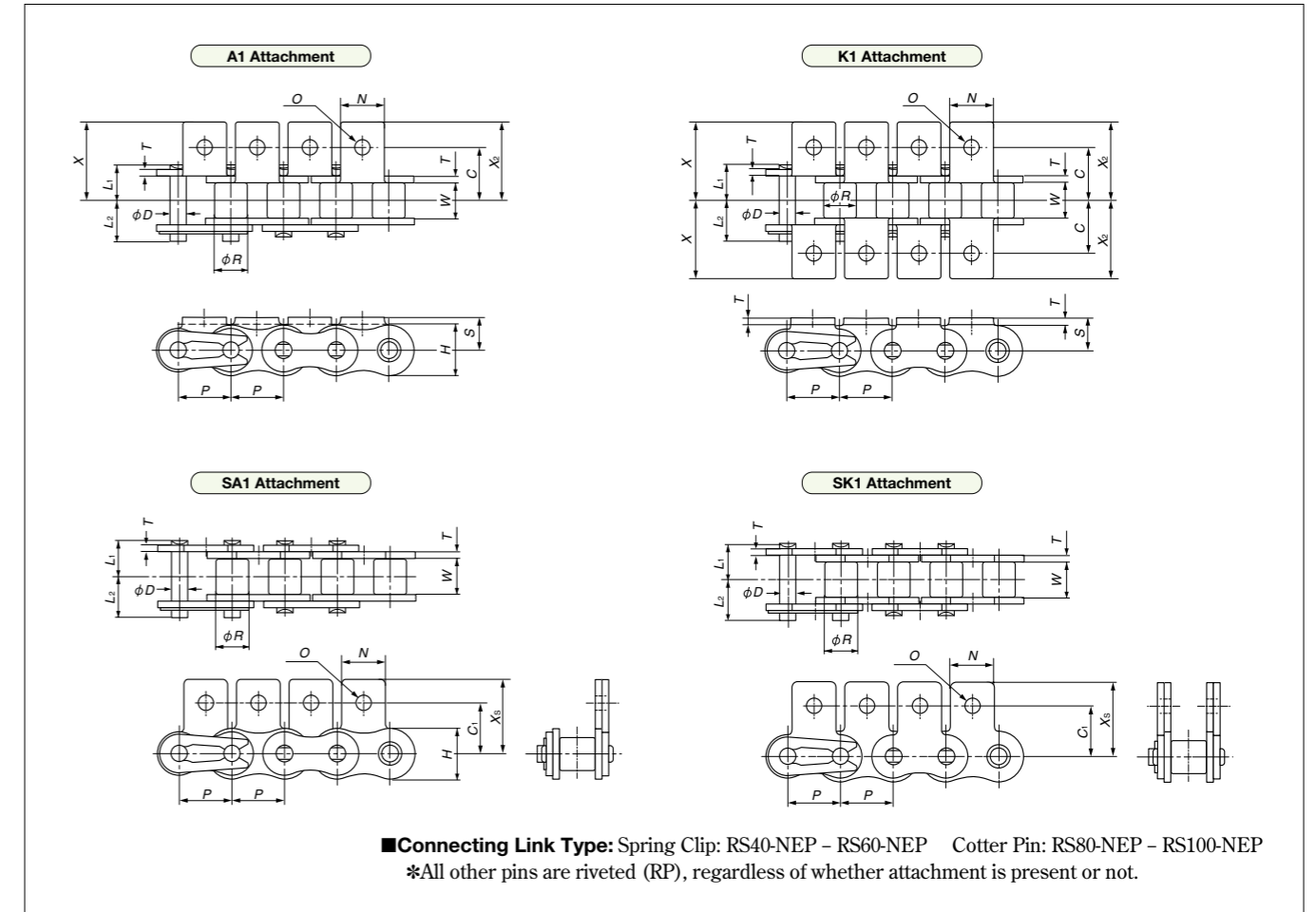

TSUBAKI Chain Number	Pitch P	Roller Diameter R	Inner Width of Inner Link W	Plate		Diameter D	Pin		Minimum Tensile Strength kN[kgf]	Maximum Allowable Load kN[kgf]	Approximate Mass kg/m
				Thickness T	Height H		L ₁	L ₂			
RS40-NEP	12.70	7.92	7.95	1.5	12.0	3.97	8.25	9.95	14.7 { 1500 }	2.65 { 270 }	0.64
RS50-NEP	15.875	10.16	9.53	2.0	15.0	5.09	10.3	12.0	23.5 { 2400 }	4.31 { 440 }	1.04
RS60-NEP	19.05	11.91	12.70	2.4	18.1	5.96	12.85	14.75	35.3 { 3600 }	6.28 { 640 }	1.53
RS80-NEP	25.40	15.88	15.88	3.2	24.1	7.94	16.25	19.25	60.8 { 6200 }	10.7 { 1090 }	2.66
RS100-NEP	31.75	19.05	19.05	4.0	30.1	9.54	19.75	22.85	93.2 { 9500 }	17.1 { 1740 }	3.99

TSUBAKI Chain Number	Attachments								Mass per Attachment kg		Links per Unit
	C	C ₁	N	O	S	X	X ₂	X ₃	A/SA Attachments	K/SK Attachments	
RS40-NEP	12.7	12.7	9.5	3.6	8.0	17.8	17.8	17.40	0.002	0.004	240
RS50-NEP	15.9	15.9	12.7	5.2	10.3	23.4	23.4	23.05	0.003	0.006	192
RS60-NEP	19.05	18.3	15.9	5.2	11.9	28.2	28.2	26.85	0.007	0.014	160
RS80-NEP	25.4	24.6	19.1	6.8	15.9	36.6	36.6	35.45	0.013	0.026	120
RS100-NEP	31.75	31.8	25.4	8.7	19.8	44.9	44.9	44.00	0.026	0.052	96

1. Made-to-order.
2. O is marginally smaller.

Operating Temperature Range : -10°C - 150°C

(Lubricate with a high temperature lubricant when using above 60°C. Consult Tsubaki when using in temperatures beyond the ranges given.)

Selection/Handling:

Refer to the TSUBAKI Chain Products General Catalog (Catalog No. CHAIN 001-1) for information on selection and handling.

Precautions on Use:

Electrical corrosion may occur when steel chains are used with stainless steel sprockets, promoting premature wear. Avoid mutual contact as much as possible.

BS/DIN Conveyor Series is available. Please contact TSUBAKI representative.

NEP ANSI Double pitch conveyor Series

Chain Numbering Example RF2050R-NEP-1L A2

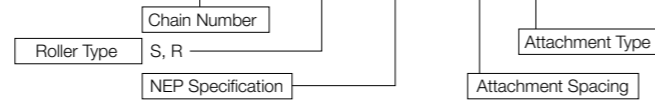

■Connecting Link Type: Spring Clip: RF2040-NEP – RF2060-NEP Cotter Pin: RF2080-NEP, RF2100-NEP
 *All other pins are riveted (RP), regardless of whether attachment is present or not.
 *Sizes over RF2080-NEP have cotter pins on both ends of the offset link.

TSUBAKI Chain Number	Roller Type	Pitch P	Roller Dia.		Inner Width of Inner Link W	Plate			Pin				Approximate Mass kg/m		Minimum Tensile Strength kN{kgf}	Maximum Allowable Load kN{kgf}
			S Roller R ₁	R Roller R ₂		Thickness T	Height H	Dia. D	L ₁	L ₂	Offset Pin Length L	S Roller	R Roller			
RF2040-NEP	S, R	25.40	7.92	15.88	7.95	1.5	12.0	3.97	8.25	9.95	18.2	0.51	0.87	14.7 {1500}	2.65 { 270}	
RF2050-NEP		31.75	10.16	19.05	9.53	2.0	15.0	5.09	10.30	12.0	22.6	0.84	1.30	23.5 {2400}	4.31 { 440}	
RF2060-NEP		38.10	11.91	22.23	12.70	3.2	17.2	5.96	14.55	16.55	31.5	1.51	2.19	35.3 {3600}	6.28 { 640}	
RF2080-NEP		50.80	15.88	28.58	15.88	4.0	23.0	7.94	18.30	20.90	41.9	2.41	3.52	60.8 {6200}	10.7 {1090}	
RF2100-NEP		63.50	19.05	39.69	19.05	4.8	28.6	9.54	21.80	24.50	49.0	3.54	5.80	93.2 {9500}	17.1 {1740}	

TSUBAKI Chain Number	Attachments												Mass per Attachment kg		Links per Unit
	C	C ₁	C ₂	K	N	O	O ₁	S	T	X	X ₂	X _s	A/SA Attachment	K/SK Attachment	
RF2040-NEP	12.7	11.1	13.6	9.5	19.1	3.6	5.2	9.1	1.5	19.3	17.6	19.8	0.003	0.006	120
RF2050-NEP	15.9	14.3	15.9	11.9	23.8	5.2	6.8	11.1	2.0	24.2	22.0	24.6	0.006	0.012	96
RF2060-NEP	21.45	17.5	19.1	14.3	28.6	5.2	8.7	14.7	3.2	31.5	28.2	30.6	0.017	0.034	80
RF2080-NEP	27.8	22.2	25.4	19.1	38.1	6.8	10.3	19.1	4.0	40.7	36.6	40.5	0.032	0.064	60
RF2100-NEP	33.35	28.6	31.8	23.8	47.6	8.7	14.3	23.4	4.8	49.9	44.9	50.4	0.060	0.120	48

- Made-to-order.
- O, O₁ dimensions are marginally smaller.

■Operating Temperature Range : -10°C – 150°C

(Lubricate with a high temperature lubricant when using above 60°C. Consult Tsubaki when using in temperatures beyond the ranges given.)

■Selection/Handling:

Refer to the TSUBAKI Chain Products General Catalog (Catalog No. CHAIN 001-1)

■Precautions on Use:

Electrical corrosion may occur when steel chains are used with stainless steel sprockets, promoting premature wear.
 Avoid mutual contact as much as possible.

NEP Large Size Conveyor

Chain Numbering Example RF03100F-DT-NEP-1L A2

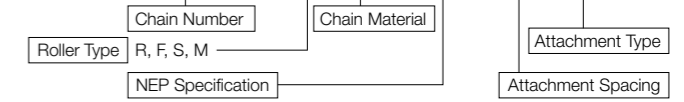

***Refer to pg. 9 for attachment dimensions.**

TSUBAKI Chain Number	Roller Type	Pitch P	Roller Dimensions								Inner Width of Inner Link W	Plate		Pin			Approximate Mass kg/m				Standard Series Ave. Tensile Strength kN{kgf}		
			R Roller		F Roller				S Roller Dia. R	M Roller Dia. R		Height H	Thickness T	Dia. D	L _{1+L₂}	L ₁	L ₂	R Roller	F Roller	S Roller		M Roller	
RF03075-NEP	R,F,S	75	31.8	15.5	31.8	42	12	1.8	4.3	15.9	-	16.1	22	3.2	8.0	38	18	20	2.8	2.9	1.8	-	29
RF03100-NEP	R,F,S	100	-	-	-	-	-	-	-	-	-	-	-	-	-	-	-	-	2.4	2.5	1.6	-	{3000}
RF05075-NEP	S	75	-	-	-	-	-	-	-	-	-	-	-	-	-	-	-	-	-	-	4.3	-	-
RF05100-NEP	R,F,S	100	40	19	40	50	14	2.5	4.5	22.2	-	22	32	4.5	11.3	53.5	25	28.5	5.2	5.4	3.8	-	69
RF05125-NEP	R,F,S	125	-	-	-	-	-	-	-	-	-	-	-	-	-	-	-	-	4.5	4.6	3.4	-	{7000}
RF05150-NEP	R,F,S	150	-	-	-	-	-	-	-	-	-	-	-	-	-	-	-	-	4.2	4.4	3.3	-	-
RF08125-NEP	R,F,S	125	44.5	23	44.5	55	18	2.5	6.5	22.2	25.4	27	28.6	6.3	11.3	65.5	31	34.5	5.9	6.2	4.2	-	78
RF08150-NEP	R,F,S	150	-	-	-	-	-	-	-	-	-	-	-	-	-	-	-	-	5.6	5.8	4.0	-	{8000}
RF10100-NEP	R,S,M	100	-	-	-	-	-	-	-	-	-	-	-	-	-	-	-	-	10.0	-	7.0	7.3	113
RF10125-NEP	R,F,S,M	125	50.8	27	50.8	65	20	3	7	29	31.8	30	38.1	6.3	14.5	69	33	36	8.7	9.0	6.3	6.5	{11500}
RF10150-NEP	R,F,S,M	150	-	-	-	-	-	-	-	-	-	-	-	-	-	-	-	-	8.0	8.3	5.9	6.1	-
RF12200-NEP	R,F,S,M	200	-	-	-	-	-	-	-	-	-	-	-	-	-	-	-	-	11.6	12.1	8.3	8.6	186
RF12250-NEP	R,F,S,M	250	65	32	65	80	24	4	8	34.9	38.1	37.1	44.5	7.9	15.9	83.5	40.5	43	10.4	10.8	7.8	8.0	{19000}
RF17200-NEP	R,F,S,M	200	-	-	-	-	-	-	-	-	-	-	-	-	-	-	-	-	20	21	12	13	-
RF17250-NEP	R,F,S,M	250	80	44	80	100	34	5	12	40.1	44.5	51.4	50.8	9.5	19.1	109.5	51.5	58	17	18	11	12	245
RF17300-NEP	R,F,S,M	300	-	-	-	-	-	-	-	-	-	-	-	-	-	-	-	-	16	16	11	11	{25000}
RF26200-NEP	S,M	200	-	-	-	-	-	-	-	-	-	-	-	-	-	-	-	-	-	-	16	17	-
RF26250-NEP	R,F,S,M	250	-	-	-	-	-	-	-	-	-	-	-	-	-	-	-	-	26	27	15	16	314
RF26300-NEP	R,F,S,M	300	100	50	100	125	38	6	13	44.5	50.8	57.2	63.5	9.5	22.2	116.5	55.5	61	23	24	14	15	{32000}
RF26450-NEP	R,F,S,M	450	-	-	-	-	-	-	-	-	-	-	-	-	-	-	-	-	19	19	13	13	-
RF36250-NEP	S,M	250	-	-	-	-	-	-	-	-	-	-	-	-	-	-	-	-	-	-	25	26	-
RF36300-NEP	R,F,S,M	300	-	-	-	-	-	-	-	-	-	-	-	-	-	-	-	-	40	42	23	24	476
RF36450-NEP	R,F,S,M	450	125	56	125	150	42	7	14	50.8	57.2	66.7	76.2	12.7	25.4	146	68	78	32	33	21	21	{48500}
RF36600-NEP	R,F,S,M	600	-	-	-	-	-	-	-	-	-	-	-	-	-	-	-	-	28	29	19	20	-

- Made-to-order

■Operating Temperature Range : -20°C – 200°C

■Selection/Handling:

Refer to the TSUBAKI Chain Products General Catalog (Catalog No. CHAIN 001-1)

■Precautions on Use:

Electrical corrosion may occur when steel chains are used with stainless steel sprockets, promoting premature wear.
 Avoid mutual contact as much as possible.

NEP Large Size Conveyor

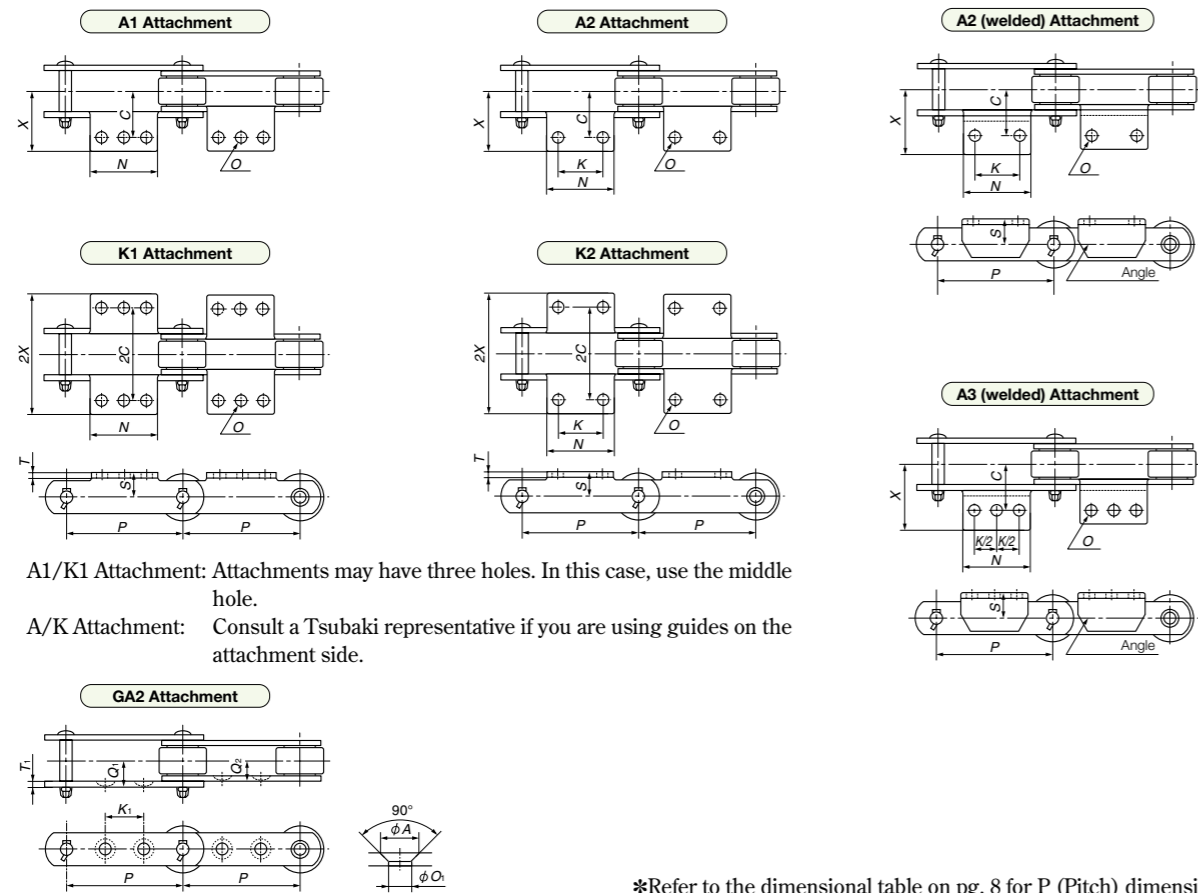

A1/K1 Attachment: Attachments may have three holes. In this case, use the middle hole.
 A/K Attachment: Consult a Tsubaki representative if you are using guides on the attachment side.

*Refer to the dimensional table on pg. 8 for P (Pitch) dimensions.

TSUBAKI Chain Number	Attachment (A, K)								Attachment (GA2)								Matching Standard Attachments with Roller Type					A Attachment Mass kg		
	T	S	C	X	K	N	O	Bolt	K ₁	T ₁	Q ₁	Q ₂	A	O ₁	Max. Bolt Length			A1	A2	A2 (welded)	A3 (welded)		GA2	
															Bolt	Outer Link	Inner Link							
RF03075-NEP	3.2	20	30	46	30	55	10	M8	30	3.2	15.5	11.5	13.5	8	M6	26	19	R, F, S	R, F, S	-	-	R, S	0.06	
RF03100-NEP					40	65			50							R, F, S	R, F, S	-	-	R, S	0.07			
RF05075-NEP	4.5	22	35	47	30	55	10	M8	-	4.5	21	15.5	15	10	M8	36	26	S	S	-	-	-	0.06	
RF05100-NEP					40	65			40							R, F, S	R, F, S	-	-	R, S	0.07			
RF05125-NEP					50	75			50							R, F, S	R, F, S	-	-	R, F, S	0.08			
RF05150-NEP					60	85			60							R, F, S	R, F, S	-	-	R, F, S	0.10			
RF08125-NEP	6.3	28	50	64	50	80	12	M10	-	6.3	27	20	20	12	M10	45	31	R, F, S	R, S, M	-	-	-	0.19	
RF08150-NEP					60	90			60							R, F, S	R, F, S, M	-	-	R, F, S	0.23			
RF10100-NEP	6.3	28	50	67	40	70	12	M10	30	6.3	28.5	21.5	20	12	M10	49	35	R, S, M, R, S, M	-	-	-	S, M	0.16	
RF10125-NEP					40	70			40							R, F, S, M, R, F, S, M	-	-	R, S, M	0.18				
RF10150-NEP					60	90			60							R, F, S, M, R, F, S, M	-	-	R, F, S, M	0.20				
RF12200-NEP	7.9	38	60	79	80	120	15	M12	80	7.9	35.5	26.5	26	15	M12	63	45	R, F, S, M, R, F, S, M	-	-	-	R, F, S, M	0.44	
RF12250-NEP					125	170			125							R, F, S, M, R, F, S, M	-	-	R, F, S, M	0.61				
RF17200-NEP					80	120			70							R, F, S, M, R, F, S, M	-	-	R, F, S, M	0.64				
RF17250-NEP	9.5	45	75	100	125	170	15	M12	110	9.5	45.5	35	26	15	M12	81	61	R, F, S, M, R, F, S, M	-	-	-	R, F, S, M	0.88	
RF17300-NEP					180	220			150							-	R, F, S, M	-	-	R, F, S, M	1.26			
RF26200-NEP	9.5	55	80	108	80	120	15	M12	-	9.5	48.5	38	26	15	M12	88	67	-	S, M	-	-	-	0.74	
RF26250-NEP					125	170			-							R, F, S, M	-	-	-	1.01				
RF26300-NEP					180	220			140							R, F, S, M	-	-	R, F, S, M	1.34				
RF26450-NEP					123.5	280			220							-	R, F, S, M, R, F, S, M, R, F, S, M	-	-	R, F, S, M	3.19			
RF36250-NEP	-	-	-	-	-	-	-	-	-	-	-	-	-	-	-	-	-	-	-	-	-	-	-	
RF36300-NEP	10	70	100	160	100	160	19	M16	-	12.7	60	46	32	19	M15	105	75	-	-	R, F, S, M	-	-	-	2.4
RF36450-NEP					280	330			220							-	R, F, S, M, R, F, S, M, R, F, S, M	-	-	R, F, S, M	4.9			
RF36600-NEP					360	410			300							-	R, F, S, M, R, F, S, M, R, F, S, M	-	-	R, F, S, M	6.1			

1. The mass of the A Attachments shown in the table are per attachment (kg). For K Attachments, multiply by two.

For Safe Use

⚠ WARNING Obey the following points in order to prevent hazardous situations.

- Do not use chains and accessories (accessories and parts) for anything other than their original purpose.
- Never perform additional processing on the chain.
 - Do not anneal the various parts of the chain.
 - Do not clean the chain with either acid or alkali, as they may cause cracking.
 - Do not electroplate the chain or its parts, as they may cause cracking due to hydrogen embrittlement.
 - Do not weld the chain, as the heat may cause cracking or a reduction in strength.
 - When heating or cutting the chain with a torch, remove the links immediately adjacent and do not use them again.
- When there is need to replace a lost or damaged portion of a chain, always replace the whole chain with a new product rather than replacing only the lost or damaged portion.
- When using a chain on suspension equipment, establish a safety manual, etc., and strictly prevent entry to the area directly below the suspended object.
- Always employ hazard protection devices for the chain and sprocket (safety cover, etc.).
- If a substance that can cause embrittlement cracking (acid, strong alkali, battery fluid, etc.) adheres to the chain, stop using the chain immediately and replace it with a new one.
- During installation, removal, maintenance inspection and lubrication of the chain:
 - Perform the operation according to the instruction manual or this catalog.
 - Always turn off the power switch to the device and make sure that it cannot be turned on accidentally.
 - Anchor the chain and parts so that they cannot move freely.
 - Perform cutting and connecting procedures properly using a press or other special tool.
 - Wear clothing and employ protective devices that are appropriate to the job (safety glasses, gloves, safety shoes, etc.).
 - Only allow experienced personnel to perform chain replacement procedures.
- In order to prevent hazards, damage, or injury when cutting a Leaf Chain, always install hazard protection devices (safety device, etc.) on the suspension equipment employing the Leaf Chain.

⚠ CAUTION Obey the following points in order to prevent accidents.

- Only handle the chain after thoroughly understanding its structure and specifications.
- When installing a chain, inspect it in advance to confirm that it has not been damaged in transport.
- Be sure to perform regular maintenance inspections on the chain and sprocket.
- Chain strength varies according to manufacturer. When selecting a chain based on a Tsubaki catalog, always use the corresponding Tsubaki product.
- Minimum tensile strength refers to the failure point when the corresponding load is applied to the chain once and does not refer to the allowable operational load.

Warranty

1. LIMITED WARRANTY

Products manufactured by Seller: (a) conform to the design and specifications, if any, expressly agreed to in writing by Seller; and (b) are free of defects in workmanship and materials at the time of shipment. The warranties set forth in the preceding sentence are exclusive of all other warranties, express or implied, and extend only to Buyer and to no other person. ALL WARRANTIES OF MERCHANTABILITY OR FITNESS FOR A PARTICULAR PURPOSE ARE HEREBY EXCLUDED.

incidental damages, including, but not limited to, damages resulting from personal injury, death or damage to or loss of use of property.
 (d) Repair, alteration, neglect or misuse of the products shall void all applicable warranties.

2. NON-RELIANCE

Buyer is not relying upon any advice, representations or warranties (except the warranties expressly set forth above) of Seller, or upon Seller's skill or judgment regarding the Seller's products.
 Buyer is solely responsible for the design and specifications of the products, including without limitation, the determination of suitability for Buyer's application of the products.

4. INDEMNIFICATION

Buyer will indemnify, defend and hold Seller harmless from all loss, liability, damage and expense, including attorneys' fees, arising out of any claim (a) for infringement of any patent, trademark, copyright, misappropriation of trade secrets, unfair competition or similar charge by any products supplied by Seller in accordance with the design or specifications furnished by Buyer, or (b) arising out of or connected with the products or any items into which the products are incorporated, including, but not limited to, any claim for product liability (whether or not based on negligence or strict liability of Seller), breach of warranty, breach of contract or otherwise.

3. CLAIMS

(a) Any claim relating to quantity or type shall be made to Seller in writing within 7 days after receipt of the products; any such claim made thereafter shall be barred.
 (b) Any claim under the above-stated Limited Warranty shall be made to Seller in writing within three (3) months after receipt of the products; any such claim made thereafter shall be barred.
 (c) Seller's liability for breach of warranty or otherwise is limited to repair or replacement, at Seller's option, of non-conforming or defective products. Buyer waives all other remedies, including, but not limited to, all rights to consequential, special or

5. ENTIRE AGREEMENT

These terms and conditions constitute the entire agreement between Buyer and Seller and supersede any inconsistent terms and conditions, whether contained in Buyer's purchase order or otherwise, and whether made heretofore or hereafter.
 No statement or writing subsequent to the date hereof which purports to modify or add to the terms and conditions hereof shall be binding unless consented to in writing, which makes specific reference hereto, and which has been signed by the party against which enforcement thereof is sought. Seller reserves the right to change these terms and conditions without prior notice.



TSUBAKIMOTO CHAIN CO.

Headquarters

Nakanoshima Mitsui Building,
 3-3-3, Nakanoshima, Kita-ku,
 Osaka, 530-0005, Japan
 Phone : 81-6-6441-0011
 Facsimile : 81-6-6441-0489
 Internet:
<http://tsubakimoto.com>

Chain Division

Chain Sales Department
 1-3, Kannabidai 1-chome
 Kyotanabe, Kyoto 610-0380, Japan
 Phone : 81-774-64-5023/4
 Facsimile : 81-774-64-5212



Kyotanabe Plant

For further information please
 contact the Chain Division.

Affiliated Companies:
U.S. TSUBAKI, INC.

301 E. Marquardt Drive
 Wheeling, IL 60090
 U.S.A.
 Phone : 1-847-459-9500
 Facsimile : 1-847-459-9515

TSUBAKIMOTO EUROPE B.V.

Aventurijn 1200
 3316 LB, Dordrecht
 The Netherlands
 Phone : 31-78-6204000
 Facsimile : 31-78-6204001

TSUBAKI of CANADA LIMITED

1630 Drew Road
 Mississauga, Ontario, L5S 1J6
 Canada
 Phone : 1-905-676-0400
 Facsimile : 1-905-676-0904

TSUBAKIMOTO SINGAPORE PTE. LTD.

25 Gul Lane
 Jurong
 Singapore 629419
 Phone : 65-6861-0422/3/4
 Facsimile : 65-6861-7035

TSUBAKI AUSTRALIA PTY. LTD.

Unit E. 95-101 Silverwater Road
 Silverwater, N.S.W. 2128
 Australia
 Phone : 61-2-9648-5269
 Facsimile : 61-2-9648-3115

TAIWAN TSUBAKIMOTO CO.

No. 7 Feng Sun Keng
 Kuei Shan-Hsiang, Taoyuan-Hsien
 Taiwan
 Phone : 886-33-293827/8/9
 Facsimile : 886-33-293065

TSUBAKIMOTO U.K. LTD.

Osier Drive, Sherwood Park
 Annesley,
 Nottingham NG15 0DX U.K.
 Phone : 44-1623-688-700
 Facsimile : 44-1623-688-789

TSUBAKIMOTO (THAILAND) CO., LTD.

No.1001,10th Fl.,
 The Offices at Centralworld
 999/9 Rama I Rd.,
 Pathumwan, Bangkok 10330
 Thailand
 Phone : 66-2-264-5354/5/6
 Facsimile : 66-2-251-3912

**TSUBAKIMOTO CHAIN TRADING
 (SHANGHAI) CO., LTD.**

Room 1712, Lippo Plaza,
 No.222 Huai Hai Zhong Rd.
 Shanghai, China 200021
 Phone : 86-21-5396-6651/2
 Facsimile : 86-21-5396-6628

KOREA CONVEYOR IND. CO., LTD.

72-1 Onsoo-Dong
 Kuro-ku, Seoul,
 Korea
 Phone : 82-2-2619-4711
 Facsimile : 82-2-2619-0819

Distributed by:

TSUBAKI NEP CHAIN SUPERIOR CORROSION RESISTANCE

Patent Pending

